

**SEZIONE ATTREZZI  
TOOLS SECTION**

**bwzetti®**



**PIAGGIO - VESPA - APRILIA - GILERA**



**CHIAVI PER CANDELE E RUOTE  
SPANNERS FOR PLUG AND WHEEL**

Conf. / Pack 2 pcs

**Art. 4870**

Es. - hex. mm. 11 x 13 x 21  
**VESPA SPECIAL model  
PRIMAVERA - ET3 model**

**Art. 4874**

Es. - hex. mm. 13 x 17 x 21  
**VESPA SPECIAL model  
PRIMAVERA - ET3 model**

**Art. 4881**

Es. - hex. mm. 13 x 11 x 21  
**VESPA SUPER - SPRINT  
PX - PE model**

**Art. 4827**

**NEW**

CHIAVE CANDELA CON GOMMINO  
SPARK PLUG SPANNER WITH RUBBER

L= mm 115 Es. - hex. mm. 16

**VESPA PRIMAVERA 125/150 4t 3V**

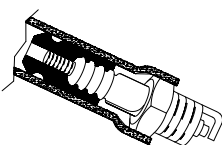
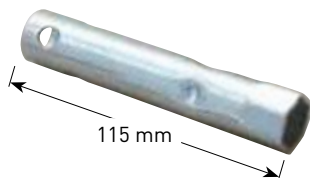

**Art. 5232**

ESTRATTORE VOLANO  
FLY-WHEEL PULLER

Ø mm. 26 passo-pitch 1

**PIAGGIO -VESPA 50 2t/4t**

**APRILIA - PEUGEOT - 50CC 2t/4t  
(KOKUSAN - MITSUBA)**

Conf. / Pack 2 pcs



**Art. 5242**

ESTRATTORE VOLANO  
FLY-WHEEL PULLER

Ø mm. 28 passo-pitch 1

**PIAGGIO - GILERA**

**50/125/150/200 2t - 4t**

**LML - 125 - 150 - 200**

**(MOTOPLATT)**

Conf. / Pack 2 pcs



**Art. 5255**

ESTRATTORE VOLANO  
FLY-WHEEL PULLER

Ø mm. 17 passo-pitch 1

**CIAO - SI**

Conf. / Pack 1 pc



**Art. 5260**

ESTRATTORE VOLANO  
FLY-WHEEL PULLER

Ø mm. 24 passo-pitch 1

**VESPA PK**

Conf. / Pack 1 pc



**Art. 5283**

ESTRATTORE CON DOPPIO FILETTO ESTERNO DESTRO  
PULLER WITH DOUBLE RIGHT OUTER THREAD

Ø mm. 26 passo-pitch 1

Ø mm. 28 passo-pitch 1

**PIAGGIO - VESPA 125/150 2t - 4t**

Conf. / Pack 2 pcs



**Art. 5336**

ESTRATTORE VOLANO FILETTO INTERNO  
FLY-WHEEL PULLER WITH INTERNAL THREAD

Ø mm.35 passo-pitch 1

PER MOTORI/FOR ENGINES

**PIAGGIO 250/300/400/500 4t**

Conf. / Pack 1 pc



**Art. 5337**

ESTRATTORE VOLANO FILETTO INTERNO COMPLETO DI PUNTALE  
FLY-WHEEL PULLER WITH INTERNAL THREAD COMPLETE WITH ROD

Ø mm. 30 passo-pitch 1

PER/FOR **VESPA PRIMAVERA 125-150cc**

DAL/FROM 2014

**VESPA SPRINT 125 - 150cc**

**PIAGGIO LIBERTY 125 - 150cc**

MOTORI / ENGINES 4t 3V

**VESPA LX - S 125 - 150 4t**

Conf. / Pack 1 pc



PIAGGIO - VESPA - APRILIA - GILERA

Art. 5421

ESTRATTORE SMONTAGGIO FRIZIONE  
PULLER FOR CLUTCH DISASSEMBLING

Ø mm. 26 passo-pitch 1

VESPA 50

PRIMAVERA - ET3 125

VESPA PK 50/125

Conf. / Pack 2 pcs



Art. 5424

SPINGIDISCHI PER SMONTAGGIO FRIZIONE  
PLATE PUSHING TOOL FOR CLUTCH DISASSEMBLY

VESPA 50/125/150/200

(O.R. 0030631)

Conf. / Pack 1 pc



Art. 5429

ATTREZZO PER SMONTAGGIO GHIERA FRIZIONE  
TOOL FOR DISASSEMBLY CLUTCH RING NUT

VESPA PX - PE

(O.R. TOC30627)

Conf. / Pack 1 pc



Art. 5433

ATTREZZO SMONTAGGIO RUBINETTO BENZINA  
TOOL FOR DISASSEMBLY PETROL TWIST GRIPS

VESPA

TUTTI I MODELLI / ALL MODELS

Conf. / Pack 1 pc



Art. 5419

ATTREZZO PER SERRAGGIO GHIERA STERZO  
TOOL FOR TIGHTENING THE STEERING NUT

SCOOTERS PIAGGIO - GILERA



CHIAVI SMONTAGGIO FILTRI OLIO

OIL FILTERS TOOLS

Art. 5186

PER FILTRI Ø 76 CON 14 ANGOLI - INNESTO QUADRO

FOR FILTERS Ø 76 WITH 14 FLUTES - SQUARE CLUTCH

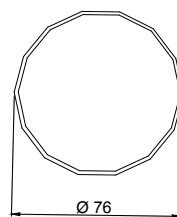

Art. 5197

PER FILTRI Ø 76 CON 12 INNESTI RIGATI

FOR FILTERS Ø 76 WITH 12 SCORED CLUTCHES



Art. 5106

ATTREZZO PER FILTRO MOTORI PIAGGIO 300-400-500cc 4t

DOPPIO USO Ø 76

PER CARTUCCE POLIGONALI E A INNESTI RIGATI

PIAGGIO 300-400-500cc 4s ENGINES FILTER TOOL

DOUBLE USE Ø 76

FOR SCORED CLUTCHES AND POLYGONAL CARTRIDGES

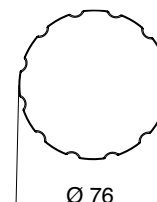
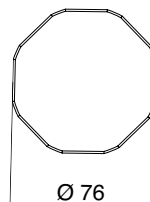

**PIAGGIO - VESPA - APRILIA - GILERA**

**Art. 5110**

ATTREZZO SMONTA FILTRO OLIO  
**MOTORI PIAGGIO da 125 a 300 cc. 4t**  
**Ø 49 mm CON 14 INNESTI**

**PIAGGIO ENGINES from 125 to 300 cc. 4s**  
 OIL FILTER DISASSEMBLING TOOL  
**Ø 49 mm - 14 FLUTES**

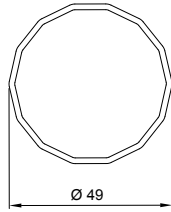

**Art. 5437**

ATTREZZO BLOCCA PULEGGIA ANTERIORE  
 FRONT PULLEY LOCKING TOOL

**MOTORI / ENGINES 4t 3V**  
**VESPA PRIMAVERA 125-150cc**  
**VESPA SPRINT 125 - 150cc**  
**PIAGGIO LIBERTY 125 - 150cc**

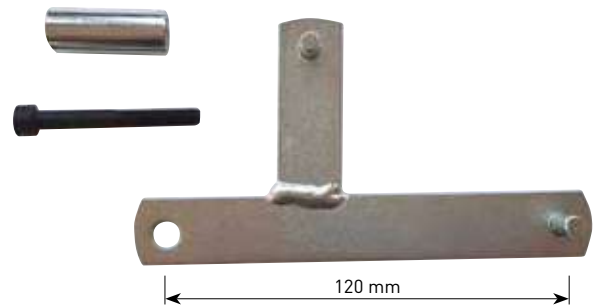

**Art. 5112**

ATTREZZO PER FILTRO  
**MOTORI PIAGGIO da 125 a 250 cc.**

**PIAGGIO ENGINES from 125 to 250 cc.**  
 FILTER TOOL

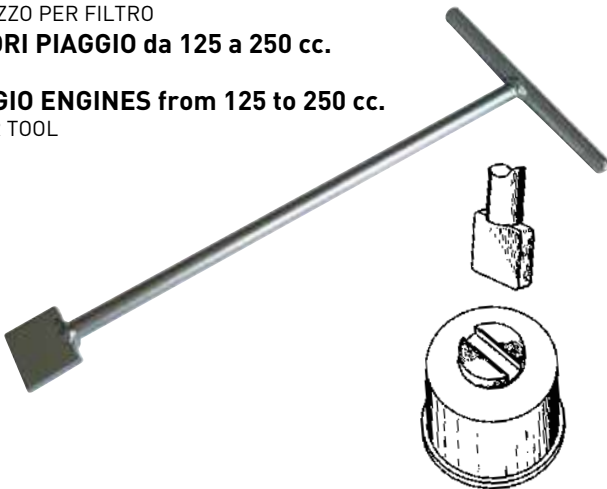

**Art. 5440**

ATTREZZO BLOCCA PULEGGIA ANTERIORE  
 FRONT PULLEY LOCKING TOOL

PER MOTORI / FOR ENGINES  
**PIAGGIO 125/150 4t 3V**

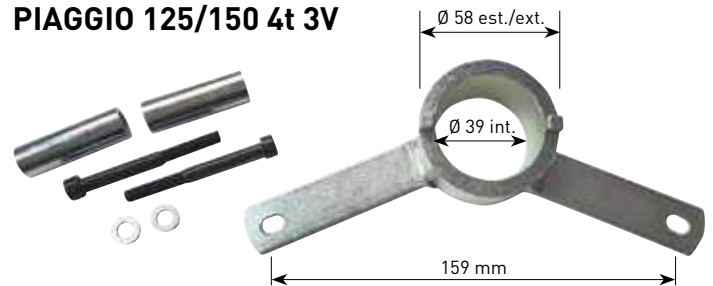

**Art. 5427**

ATTREZZO PER BLOCCARE LA FRIZIONE E PER LO SMONTAGGIO  
 DEL DADO CON ESAGONO **mm 34**

HOLDING TOOL FOR CLUTCH AND DISASSEMBLING NUT **mm 34**

**PIAGGIO - VESPA - GILERA**  
**APRILIA - 50 2t-4t**

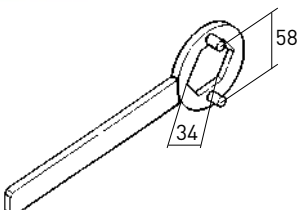

**Art. 5442**

ATTREZZO BLOCCA PULEGGIA ANTERIORE  
 FRONT PULLEY LOCKING TOOL

PER MOTORI / FOR ENGINES  
**PIAGGIO 250-300cc 4t**



PIAGGIO - VESPA - APRILIA - GILERA

Art. 5446

ATTREZZO BLOCCA PULEGGIA ANTERIORE  
FRONT PULLEY LOCKING TOOL

PER MOTORI / FOR ENGINES  
**PIAGGIO 400-500cc 4t**



Art. 5445

CHIAVE PER DADO VARIATORE POSTERIORE  
REAR VARIATOR NUT WRENCH

PER MOTORI / FOR ENGINES  
**PIAGGIO 250cc**

ES./HEX. mm. 46



Art. 5425

ATTREZZO BLOCCA PULEGGIA ANTERIORE  
FRONT PULLEY LOCKING TOOL

PER MOTORI / FOR ENGINES  
**PIAGGIO 50/125 2t-4t**



Art. 5449

CHIAVE PER DADO VARIATORE POSTERIORE  
REAR VARIATOR NUT WRENCH

PER MOTORI / FOR ENGINES  
**PIAGGIO 300cc-500cc**

ES./HEX. mm. 55



Art. 5430

ATTREZZO BLOCCA PULEGGIA ANTERIORE  
FRONT PULLEY LOCKING TOOL

PER MOTORI / FOR ENGINES  
**PIAGGIO 125-150cc 4t**



Art. 5658

ATTREZZO RITEGNO MOLLA FRIZIONE  
CLUTCH SPRING CHECK TOOL

PER MOTORI / FOR ENGINES  
**PIAGGIO - VESPA**

DA / FROM **125cc**  
A / TO **500cc 4t**



Art. 5428

ATTREZZO BLOCCA FRIZIONE  
CLUTCH LOCKING TOOL

PER MOTORI / FOR ENGINES  
**PIAGGIO 125-250-300cc 4t**



**Art. 4802**

**CHIAVE PER CANDELE DA 21 mm.  
21 mm. MOPEDS SPARK PLUGS SPANNER**

Tubo rinforzato  
Reinforced pipe

Conf. / Pack 2 pcs

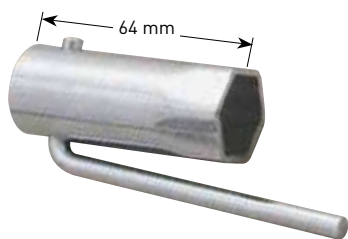

**Art. 4804**

**CHIAVE PER CANDELE DA 21 mm CON MANICO PIEGATO  
21 mm SPARK PLUGS SPANNER WITH FOLDED HANDLE**

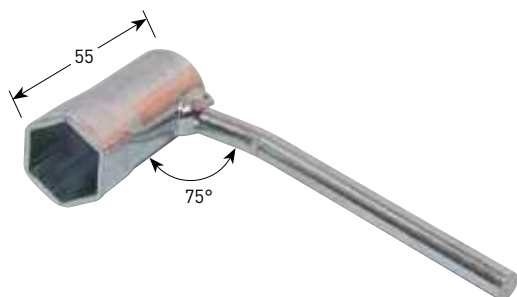

**Art. 4807**

**CHIAVE PER CANDELE STANDARD DA 21 mm.  
21 mm. STANDARD SPARK PLUGS SPANNER**

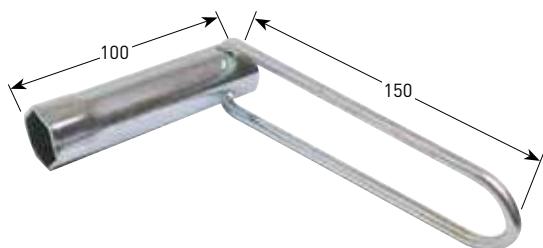

**Art. 4835**

**SPINA PER CHIAVI CANDELA  
PIN FOR SPARK PLUG SPANNERS**

Conf. / Pack 5 pcs

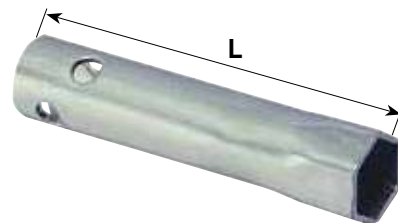
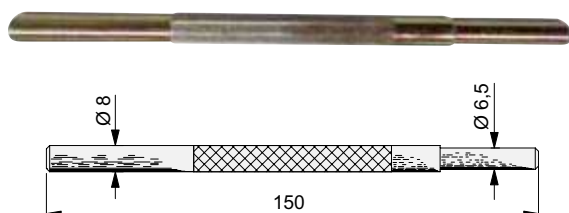

**CHIAVI CANDELA STANDARD  
STANDARD SPARK PLUG SPANNERS**

**Art. 4810** L= mm 90 Es. - hex. mm. 16

**Art. 4811** L= mm 100 Es. - hex. mm. 18

**Art. 4812** L= mm 120 Es. - hex. mm. 21

**Art. 4814** L= mm 140 Es. - hex. mm. 16

**Art. 4818**

**CHIAVE CANDELA A DOPPIO ESAGONO  
DOUBLE HEXAGON SPARK PLUG SPANNER**

L= mm 120 Es. - hex. mm. 16 - 18

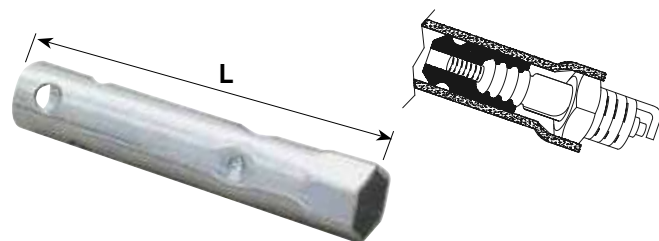
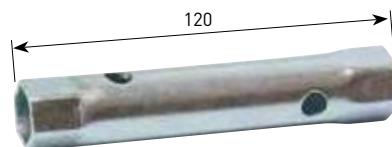

**CHIAVI CANDELA STANDARD CON GOMMINO  
STANDARD SPARK PLUG SPANNERS WITH RUBBER**

**Art. 4824** L= mm 80 Es. - hex. mm. 16

**Art. 4825** L= mm 100 Es. - hex. mm. 16

**Art. 4826** L= mm 90 Es. - hex. mm. 13

**Art. 4830** L= mm 120 Es. - hex. mm. 18

Art. 4840

**NEW**

CHIAVE CANDELA A 3 ESAGONI CON MANICO  
3 IN 1 SPARK PLUG SPANNER WITH HANDLE

L = mm 75 Es - Hex. mm. 16-18-21

DISPONIBILE DA APRILE 2023  
AVAILABLE FROM APRIL 2023



Art. 4863

CHIAVE CANDELA A PIPA  
PIPE SPARK PLUG SPANNER

L = mm 46 Es. - hex. mm. 13 x 21



Art. 4842

CHIAVE CANDELA DA 14 mm MOD. HONDA  
CON GOMMINO E PUNTALE ESAGONALE  
14 mm MOD. HONDA SPARK PLUG SPANNER  
WITH RUBBER AND HEXAGONAL PUSH ROD

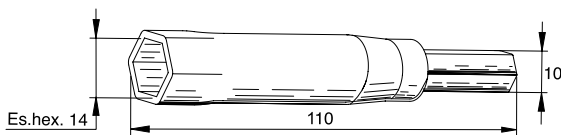

CHIAVI PER CANDELE E RUOTE  
SPANNERS FOR PLUG AND WHEEL

Conf. / Pack 2 pcs

Art. 4870

Es. - hex. mm. 11 x 13 x 21  
VESPA SPECIAL model  
PRIMAVERA - ET3 model

Art. 4874

Es. - hex. mm. 13 x 17 x 21  
VESPA SPECIAL model  
PRIMAVERA - ET3 model

Art. 4881

Es. - hex. mm. 13 x 11 x 21  
VESPA SUPER - SPRINT  
PX - PE model

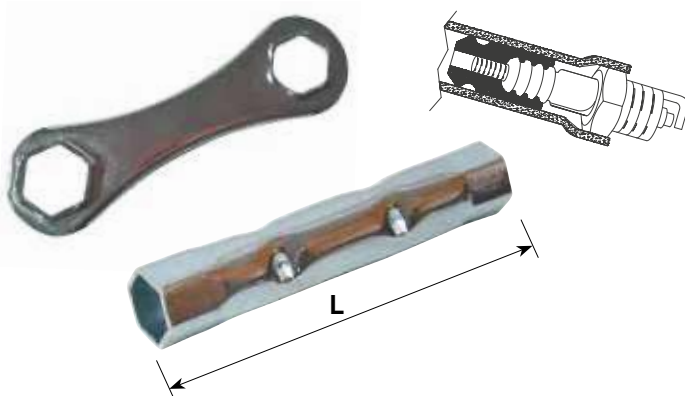

CHIAVI CANDELA A DOPPIO ESAGONO  
CON LEVA DI MANOVRA E GOMMINI  
DOUBLE HEXAGON SPARK PLUG SPANNERS WITH  
WORKING HANDLE AND RUBBERS

Art. 4854 L = mm 120 Es. - hex. mm. 16 - 18

Art. 4856 L = mm 140 Es. - hex. mm. 16 - 18

Art. 4827

CHIAVE CANDELA CON GOMMINO  
SPARK PLUG SPANNER WITH RUBBER

L = mm 115 Es. - hex. mm. 16

VESPA PRIMAVERA 125/150 4t 3V

**NEW**

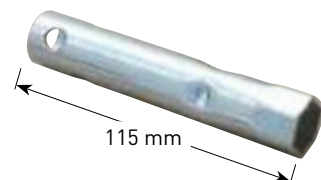

**ATTREZZO PER RIMUOVERE LA BOBINA PORTACANDELA  
TOOL TO REMOVE THE SPARK PLUG CONNECTOR**

**Art. 5200**

PER / FOR  
**BMW R1100 - R1150**  
MOTORI / ENGINES **R259**



**Art. 5201**

PER / FOR  
**BMW R1150 - R1200 - F800 -  
F650 GS Twin -  
K1200 S,R,R-Sport -  
K1300 S,R,GT**



**Art. 0540**

**TANICHETTA AUSILIARE DI ALIMENTAZIONE - CAPACITA' 1,5 LT**  
PER ALIMENTARE IL MOTORE QUANDO E' NECESSARIO RIMUOVERE IL  
SERBATOIO.  
COMPLETA DI RUBINETTO, CATENELLA, GANCIO, TAPPO E TUBO DI  
ALIMENTAZIONE.

**AUXILIARY FUEL TANK - CAPACITY 1,5 LT**  
FOR USE WHEN TUNING A MOTORCYCLE WITH GAS TANK REMOVED.  
INCLUDES TAP, HOOK, CHAIN, CAP AND FEEDING PIPE.



**Art. 0528**

**RUBINETTO IN LINEA PER TUBETTO DA 7 mm  
7 mm SMALL FUEL TAP - VALVE BY IN-LINE**

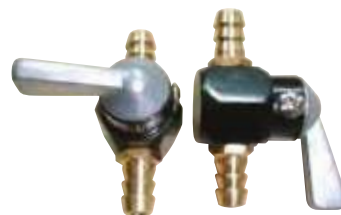

**Art. 0530**

**FASCETTA STRINGITUBO PER TUBO BENZINA  
DA Ø 10mm A 11,5mm  
SPESSORE 0,7 mm  
HOSE CLAMPS FROM Ø 10mm TO 11,5mm  
THICKNESS 0,7 mm**



Conf. / Pack 10 pcs

**Art. 0535**

**TUBO IN GOMMA 100% NBR  
Ø INTERNO 6 mm - LUNGHEZZA 1M  
PER BENZINA, GASOLIO, OLIO  
COMPLETO DI 2 FASCETTE DI FISSAGGIO  
UTILIZZABILE PER NS. ART. 0540  
100% NBR RUBBER HOSE  
INNER Ø 6 mm - LENGHT 1M  
FOR FUEL, GASOLINE, OIL  
COMPLETE WITH 2 FIXING CLAMPS  
AVAILABLE FOR OUR ART. 0540**

**NEW**

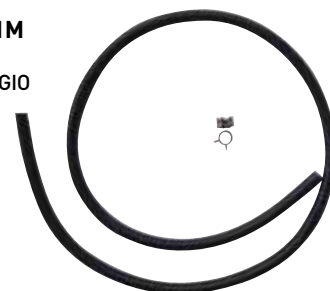

**Art. 0543**

**VASCHETTA PER RECUPERO OLIO USATO  
CON BECCUCCIO SVERSATORE  
IN POLIETILENE  
DIMENSIONI : 380x212x73 mm  
CAPACITA' : 2 Lt**

**WASTE OIL DRAIN PAN  
WITH ANTI-SPLASH LIP  
MADE IN POLYETHYLENE  
DIMENSIONS : 380x212x73 mm  
CAPACITY : 2 Lt**



**Art. 0545**

**VASCHETTA MAGNETICA  
RETTANGOLARE DA 240X140MM.  
CON GOMMA ANTISCIVOLO  
240X 140MM. RECTANGULAR  
MAGNETIC TRAY  
WITH SLIP RESISTANT RUBBER**





## Art. 0546

**VASCHETTA MAGNETICA  
CIRCOLARE Ø 150MM.  
CON GOMMA ANTISCIVOLO**

Ø 150MM. **MAGNETIC DISH  
WITH SLIP RESISTANT RUBBER**



## Art. 0550

**MINI MATERASSINO DA LAVORO  
MINI WORKMAT  
480 X 320 X 34 MM**



## Art. 0616

**LUBRIFICATORE PER CAVI FRENO/FRIZIONE  
BRAKE AND CLUTCH CABLE LUBER**

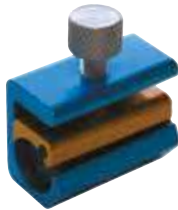

## Art. 0620

**MINI OLIATORE TASCABILE  
POCKET MINI OILER**



## Art. 4943

**SET DI 3 ATTREZZI PER RIMUOVERE GUARNIZIONI, O-RING,  
TUBI FLESSIBILI E ALTRO**

**SET OF 3 REMOVER TOOLS FOR SEAL, O-RINGS, FLEXIBLE  
HOSES AND OTHER**



## Art. 4949

**ATTREZZO SMONTAGGIO/MONTAGGIO MOLLE  
SPRINGS DISASSEMBLING/ASSEMBLING TOOL**



## Art. 5076

**COPPIA DI GANASCE PER MORSA  
PER IL SERRAGGIO DI CORPI TONDI  
CAPACITA' DA Ø 26 A Ø 70 MM  
CON VITE DI REGOLAZIONE  
DELL'ALLINEAMENTO**

**COUPLE OF VICE JAWS  
FOR ROUND PARTS LOCKING  
CAPACITY FROM Ø 26 TO Ø 70 MM  
WITH ALIGNMENT ADJUSTING  
SCREW**

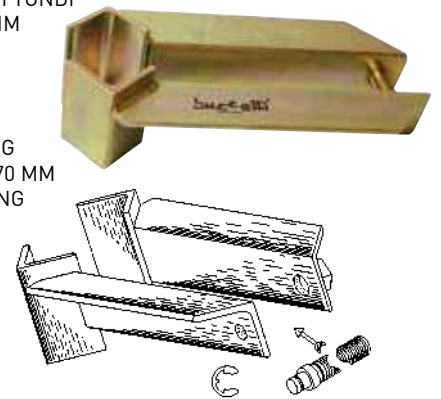

## Art. 5078

**COPPIA DI GANASCE DOLCI IN ALLUMINIO PER MORSA  
LE DUE MOLLE SERVONO PER L'APERTURA DELLE STESSE**

**COUPLE OF SOFT ALUMINIUM VICE INSERT  
THE TWO SPRINGS ALLOW THE TOOL OPENING**



**ATTREZZI RASCHIATORI IN ACCIAIO INOX  
SCRAPER TOOLS IN STAINLESS STEEL**

## Art. 5082

A = 10 mm.

## Art. 5083

A = 15 mm.

**Art. 0312**

**ATTREZZO PER LA REGOLAZIONE DELLA TENSIONE DELLE CINGHIE DENTATE**

ISTRUZIONI CON L'ATTREZZO

**OUTIL POUR AJUSTER LA TENSION DES COURROIES DENTELÉES**

MODE D'EMPLOI AVEC L'OUTIL

**TENSIONING GAUGE TOOL FOR TIMING BELTS**

USER INSTRUCTIONS INCLUDED

PER / FOR **YAMAHA TMAX 530cc**

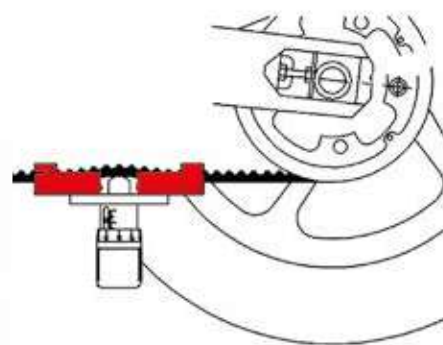
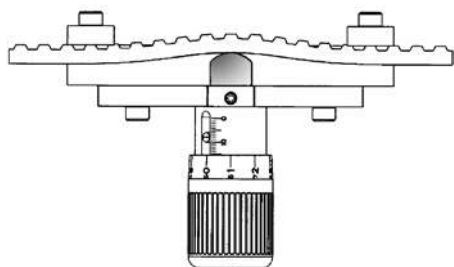

**Art. 0568**

**TESTER PER IL CONTROLLO "DELL'ALTA TENSIONE" DELLA BOBINA**

IDEALE NEI MOTORI CON SISTEMA ELETTRONICO

ISTRUZIONI CON IL TESTER

**TESTEUR POUR LE CONTRÔLE DE "L'HAUTE TENSION" DE LA BOBINE**

IDÉAL DANS LES MOTEURS AVEC SYSTÈME ÉLECTRONIQUE

MODE D'EMPLOI AVEC LE TESTEUR

**TESTER TO CHECK THE "HIGH TENSION" OF COIL**

IDEAL FOR ELECTRONIC SYSTEM ENGINES

USER INSTRUCTIONS INCLUDED

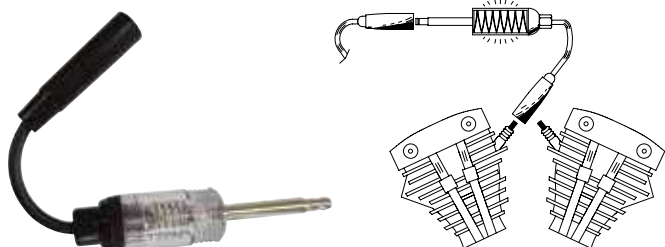

**Art. 0572**

**TESTER PER IL CONTROLLO DELL'EFFICIENZA DELLA CANDELA**

CERTIFICATO - CE -

ISTRUZIONI CON IL TESTER.

**TESTEUR POUR CONTRÔLER LE BON FONCTIONNEMENT DE BOUGIE**

CONFORME - CE -

MODE D'EMPLOI AVEC LE TESTEUR.

**TESTER TO CHECK THE SPARK PLUG EFFICIENCY**

CERTIFIED - CE -

USER INSTRUCTIONS INCLUDED.



**Art. 0570**

**TESTER PER IL CONTROLLO DELL'EFFICIENZA DELLA BOBINA CON LA SIMULAZIONE DELLA SCINTILLA**

ISTRUZIONI CON IL TESTER

**TESTEUR POUR CONTRÔLER LA CONDITION DE LA BOBINE PAR LA SIMULATION DE L'ÉTINCELLE**

MODE D'EMPLOI AVEC LE TESTEUR

**TESTER TO CHECK THE QUALITY OF COIL ACCORDING TO SPARK**

USER INSTRUCTIONS INCLUDED



**Art. 0576**

**TESTER PER IL CONTROLLO DELL' H<sub>2</sub>O NEL FLUIDO DEI FRENI**

INDICA QUANDO E' NECESSARIA LA SOSTITUZIONE DEL FLUIDO.

ISTRUZIONI CON IL TESTER.

**TESTEUR POUR CONTRÔLER L'H<sub>2</sub>O DANS LE LIQUIDE DES FREINS**

INDIQUE QUAND LA VIDANGE EST NÉCESSAIRE.

MODE D'EMPLOI AVEC LE TESTEUR.

**BRAKE FLUID TESTER**

RAPIDLY INDICATE H<sub>2</sub>O CONTENT AND CLEARLY SHOW WHEN BRAKE FLUID MUST BE CHANGED.

USER INSTRUCTIONS INCLUDED.



## Art. 5101

### TESTER SINCRONIZZATORE CARBURATORI PER MOTORI CON 2 - 3 o 4 CARBURATORI PER IL CONTROLLO DELLA POMPA CARBURANTE E L'ALLINEAMENTO / TARATURA DEI CARBURATORI.

IL KIT CONTIENE MANOMETRI CON MISURAZIONE DA 0 A 76cmHg; TUBI IN GOMMA DA 8x5x950mm; CONNETTORI

DA M5x0.8x169mm;

DA M5x0.8x53mm;

DA M5x0.8x100mm;

DA M6x0.75x53mm;

DA M6x1.0x60mm

E 1 CONNETTORE DA 6x55.

ISTRUZIONI D'USO NELLA CONFEZIONE.

### SYNCHRONISATEUR DES CARBURATEURS POUR MOTEURS AVEC 2 - 3 ou 4 CARBURATEURS

POUR LE CONTROLE DE LA POMPE ESSENCE ET L'ALIGNEMENT / ETALONNAGE DES CARBURATEURS. KIT COMPLETE DES MANOMETRES AVEC MESURAGE DE 0 A 76cmHg;

TUBES EN CAOUTCHOUC DE 8x5x950mm; CONNEXEURS DE

M5x0.8x169mm; DE M5x0.8x53mm;

DE M5x0.8x100mm; DE

M6x0.75x53mm; DE M6x1.0x60mm

ET 1 CONNEXEUR DE 6x55.

MODE D'EMPLOI AVEC LE COFFRET.

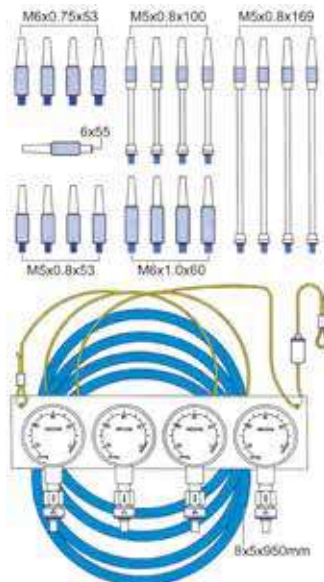

### CARBURETTOR SYNCHRONIZER TESTER FOR ENGINES WITH 2 - 3 or 4 CARBURETTORS

FOR TESTING FUEL PUMP AND CARBURETTORS ALIGNMENT / CALIBRATION.

KIT COMPLETE WITH GAUGES FROM 0 TO 76cmHg MEASURING; RUBBER HOSES OF 8x5x950mm; CONNECTORS

OF M5x0.8x169mm; OF M5x0.8x53mm; OF M5x0.8x100mm;

OF M6x0.75x53mm; OF M6x1.0x60mm AND 1 CONNECTOR OF 6x55.

USER INSTRUCTIONS INCLUDED.



## Art. 5116

### TESTER SINCRONIZZATORE CARBURATORI PER MOTOCICLI CON 2-3-4 CARBURATORI

PER IL TEST DEL CARBURATORE, POMPA BENZINA E DELLA TRASMISSIONE. CON 4 MANOMETRI LETTURA 1 bar.; 4 TUBI IN GOMMA DA Ø 8xØ 5x 750mm.; 4 TUBI DI ESTENSIONE DA 122mm. E 4 DA 52mm.; 4 CONNETTORI

DA M6x1 - 60mm. DI LUNGHEZZA E 4 CONNETTORI DA M6x0,75 - 53mm. DI LUNGHEZZA; 1 CONO CONNETTORE DA 8x40mm.

ISTRUZIONI D'USO NELLA CONFEZIONE.

### SYNCHRONISATEUR DU CARBURATEUR POUR MOTO AVEC 2-3-4 CARBURATEURS

POUR LE CONTROLE DU CARBURATEUR, POMPE ESSENCE ET DE LA TRANSMISSION. AVEC 4 MESUREURS LECTURE 1 bar.; 4 TUBES EN CAOUTCHOUC DE Ø 8xØ 5x 750mm.; 4 TUBES D'EXTENSION DE 122mm. ET 4 DE 52mm.; 4 CONNEXEURS DE M6x1 - 60mm. DE LONGUEUR ET 4 CONNEXEURS DE

M6x0,75 - 53mm. DE LONGUEUR; 1 CONE DE LIASON DE 8x40mm.

MODE D'EMPLOI AVEC LE COFFRET.

### ENGINE SYNCHRONIZER TESTER WITH 2-3-4 CARBURETORS

FOR CARBURATOR, FUEL PUMP AND TRANSMISSION TESTING.

WITH 4pcs 1bar. READING GAUGES; RUBBER HOSE 4pcs Ø 8xØ 5x 750mm.;

122mm. AND 52mm. EXTENSION TUBE 4pcs; CONE TYPE CONNECTOR

4pcs M6x1 - 60mm. LENGTH AND 4 pcs M6x0,75 - 53mm. LENGTH; 1pc

8x40mm. CONE TYPE CONNECTOR.

USER INSTRUCTIONS INCLUDED.



## Art. 5103

### TESTER PER IL CONTROLLO DELLA COMPRESSIONE NEL CILINDRO

CARATTERISTICA: DISPONE DI UNA VALVOLA DI RAPIDO SCARICO DELLA PRESSIONE E DI UN MISURATORE CON CAPACITA' DI 300 PSI. KIT COMPLETO DI MANOMETRO E TRE TUBI CON INNESTO DA 10-12-14 mm. ISTRUZIONI D'USO NELLA CONFEZIONE.

### TESTEUR POUR LE CONTRÔLE DE LA COMPRESSION DANS LE CYLINDRE

CARACTERISTIQUE: CE KIT DISPOSE D'UNE SOUPAPE D'ÉCHAPPEMENT RAPIDE DE PRESSION ET D'UNE JAUGE AVEC CAPACITEE DE 300 PSI. KIT COMPLETE DE MANOMETRE, TROIS TUYAUX AVEC ATTAQUE DE 10-12-14 mm. MODE D'EMPLOI AVEC LE COFFRET.

### COMPRESSION CYLINDER CONTROL TESTER

FEATURE: EQUIPPED WITH A PRESSURE RELEASE VALVE AND WITH A GAUGE OF 300 PSI CAPACITY. THE PACKAGING INCLUDES: GAUGE, THREE HOSES FOR 10-12-14mm APPLICATIONS.

USER INSTRUCTIONS INCLUDED.



## Art. 5117

### TESTER PER IL CONTROLLO DELLA PERDITA DI PRESSIONE NEL CILINDRO

UTILE PER UNA RICERCA DI DIFETTI O PERDITE DELLE VALVOLE, DEI PISTONI, DELLE FASCE ELASTICHE E DELLE GUARNIZIONI.

IL MANOMETRO INDICA LA PERDITA SIA IN PERCENTUALE CHE IN PSI. LA COSTANTE IMMISSIONE DI ARIA COMPRESSA PERMETTE DI INDIVIDUARE I DIFETTI ANCHE ATTRAVERSO L'ASCOLTO.

LA CONFEZIONE CONTIENE: UN MANOMETRO, UN TUBO FLESSIBILE CON ATTACCO FILETTATO M14-M18, DUE RIDUZIONI M12-M10 E UN CONNETTORE DI PROLUNGA

ISTRUZIONI D'USO NELLA CONFEZIONE.

### TESTEUR POUR LE CONTRÔLE DE LA PERTE DE PRESSION DANS LE CYLINDRE

CE TESTEUR EST UTILE POUR LA RECHERCHE DES DEFAUTS OU DES PERTES DES SOUPAPES, DES PISTONS, DES SEGMENTS DE PISTON ET DES JOINTS.

LA JAUGE INDIQUE LA PERTE EN POURCENTAGE AUSSI QUE EN PSI. LA CONSTANTE INJECTION D'AIR COMPRIME PERMIS EGALEMENT D'IDENTIFIER LES DEFAUTS AUSSI AVEC L'ECOUTE.

L'ENSEMBLE COMPREND : UN MANOMETRE, UN TUYAU AVEC ATTAQUE FILETEE M14-M18, DEUX REDUCTIONS M12-M10 ET UN CONNECTEUR DE RALLONGE. MODE D'EMPLOI AVEC LE COFFRET.

### INSPECTING CYLINDER LEAKDOWN TESTER

THIS TOOL IS USEFUL TO TEST FOR A DIAGNOSES OF FAILED OR LEAKING VALVES, PISTONS, RINGS AND GASKETS. A LARGE GAUGE INDICATES PERCENTAGE OF LEAKING RATHER THAN PSI.

THE CONSTANT SUPPLY OF COMPRESSED AIR ALLOWS FAULTS TO BE PIN-POINTED ALSO BY LISTENING THE LEAKAGE.

THE PACKAGING INCLUDES : A GAUGE, A M14-M18 FLEXIBLE THREADED ADAPTOR, TWO REDUCTIONS M12-M10 AND ONE EXTENSION CONNECTION. USER INSTRUCTIONS INCLUDED.



## Art. 5119

### POMPA MANUALE PER IL CONTROLLO DELLA DEPRESSIONE CON MANOMETRO MISURATORE

LA POMPA MISURA LA DEPRESSIONE, CREA E MANTIENE IL SOTTOVUOTO. UTILIZZO: VALVOLE CARBURATORE, PRESSIONE DEL LIQUIDO DEI FRENI, POMPA CARBURANTE, VALVOLE MOTORE, REGOLAZIONE DELLA PRESA D'ARIA, INIEZIONE ELETTRONICA.

LA CONFEZIONE INCLUDE ADATTATORI, TUBI, VASCHETTA RACCOGLI-LIQUIDO E ISTRUZIONI D'USO.

### POMPE À BRAS POUR LE CONTRÔLE DE LA DEPRESSION AVEC MANOMÈTRE DE MESURE

LA POMPE MESURE LA DEPRESSION, CRÉE ET MAINTIENT LE SOUS VIDE. APPLICATION: SOUPAPES CARBURATEUR, PRESSION LIQUIDE DES FREINS, POMPE À CARBURANT, SOUPAPES MOTEUR, REGULATION PRISE D'AIR, INJECTION ÉLECTRONIQUE.

CONTENU: ADAPTATEURS, TUBES, RÉSERVOIR RACUEILLE-LIQUIDE ET MODE D'EMPLOI.

### HAND VACUUM PUMP KIT TO CHECK DEPRESSION WITH MEASURING GAUGE

THE PUMP MEASURES THE DEPRESSION CREATES AND HOLDS VACUUM. APPLICATION: CARBURETOR VALVES, BRAKE FLUID PRESSURE, FUEL PUMP, ENGINE VALVES, AIR INTAKE CONTROL, ELECTRONIC INJECTION. PACKING CONTENTS ADAPTORS, HOSES, RESERVOIR FOR BRAKE BLEEDING & FLUID. USER INSTRUCTIONS INCLUDED.



**Art. 5111**

**ATTREZZO PER FILTRO. TIPO CON BANDA IN NYLON.**  
CAPACITA' MAX FINO A 120mm  
**STRAP TYPE OIL FILTER WRENCH. CAPACITY UP TO 120mm MAX**



**ATTREZZO PER LO SMONTAGGIO DEI FILTRI OLIO MOTORE -  
INNESTO QUADRO**  
**OIL FILTER TOOL - SQUARE CLUTCH**

**Art. 5180**

PER FILTRI DA Ø 65 A 67 - 14 ANGOLI  
FOR FILTERS Ø 65 TO 67 - 14 FLUTES

**Art. 5181**

PER FILTRI Ø 68 CON 14 ANGOLI  
FOR FILTERS Ø 68 WITH 14 FLUTES

**Art. 5182**

PER FILTRI Ø 73 CON 14 ANGOLI  
FOR FILTERS Ø 73 WITH 14 FLUTES

**Art. 5183**

PER FILTRI Ø 74 CON 15 ANGOLI  
FOR FILTERS Ø 74 WITH 15 FLUTES

**Art. 5185**

PER FILTRI DA Ø 74 A 76 CON 15 ANGOLI  
FOR FILTERS Ø 74 TO 76 WITH 15 FLUTES

**Art. 5186**

PER FILTRI Ø 76 CON 14 ANGOLI  
FOR FILTERS Ø 76 WITH 14 FLUTES  
**VALIDO PER / VALID FOR BMW**

**Art. 5188**

PER FILTRI DA Ø 75 A 77 CON 15 ANGOLI  
FOR FILTERS Ø 75 TO 77 WITH 15 FLUTES

**Art. 5197**

PER / FOR **BMW**  
ANCHE PER / ALSO FOR **GUZZI - PIAGGIO**  
PER FILTRI Ø 76 CON 12 INNESTI RIGATI  
FOR FILTERS Ø 76 WITH 12 SCORED CLUTCHES



**ATTREZZO PER FILTRI OLIO CON BANDA DI GRIPPAGGIO IN ACCIAIO**  
**OIL FILTERS TOOL WITH SEIZING STEEL DEVICE**

**Art. 5167**

DA/FROM Ø 71 A/TO 79 mm

**Art. 5168**

DA/FROM Ø 87 A/TO 95 mm

**Art. 5175**

**ATTREZZO A GRIPPAGGIO MECCANICO REGOLABILE PER  
FILTRI OLIO DA Ø 61 A 97 MM**  
**MECHANICAL ADJUSTABLE SEIZING TOOL FOR OIL FILTER  
FROM Ø 61 TO 97 MM**



**Art. 5106**

**SCOOTER APRILIA - MALAGUTI - PEUGEOT - PIAGGIO - GILERA - VESPA**

**ATTREZZO PER FILTRO MOTORI PIAGGIO 300-400-500cc 4t. A DOPPIO USO, PER CARTUCCE POLIGONALI E A INNESTI RIGATI**

**PIAGGIO 300-400-500cc 4s ENGINES FILTER TOOL WITH DOUBLE USE, FOR SCORED CLUTCHES AND POLYGONAL CARTRIDGES**

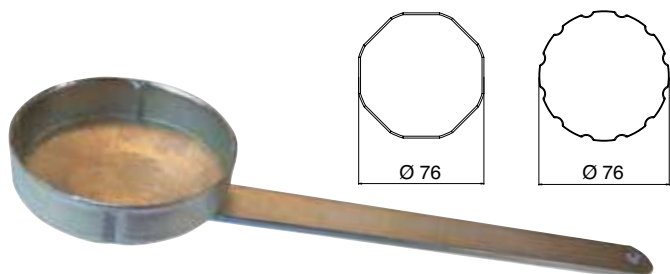

**Art. 1082**

**ROBUSTO ATTREZZO COMPRIMI MOLLA AMMORTIZZATORE CON 4 ADATTATORI DA Ø 60-66-72-75 mm**

**HEAVY-DUTY SHOCK ABSORBER SPRING COMPRESSOR TOOL WITH 4 ADAPTERS OF Ø 60-66-72-75 mm**



**Art. 5110**

**ATTREZZO SMONTA FILTRO OLIO PER SCOOTER da 125 a 300 cc. 4t  
CARTUCCIA FILTRO DI Ø 49 mm CON 14 INNESTI**

**OIL FILTER DISASSEMBLING TOOL FOR SCOOTER from 125 to 300 cc 4s Ø 49 mm - 14 FLUTES FILTER CARTRIDGES**



**Art. 1090**

**ATTREZZO COMPRIMI MOLLA AMMORTIZZATORE POSTERIORE PER SCOOTER E MINIMOTO**

**REAR COIL SPRING COMPRESSOR FOR SCOOTER AND MINIBIKE**



**Art. 5112**

**SCOOTER APRILIA - MALAGUTI - PEUGEOT - PIAGGIO-GILERA - VESPA**

**ATTREZZO PER FILTRO MOTORI PIAGGIO da 125 a 250 cc.**

**PIAGGIO ENGINES FROM 125 TO 250 cc. FILTER TOOL**

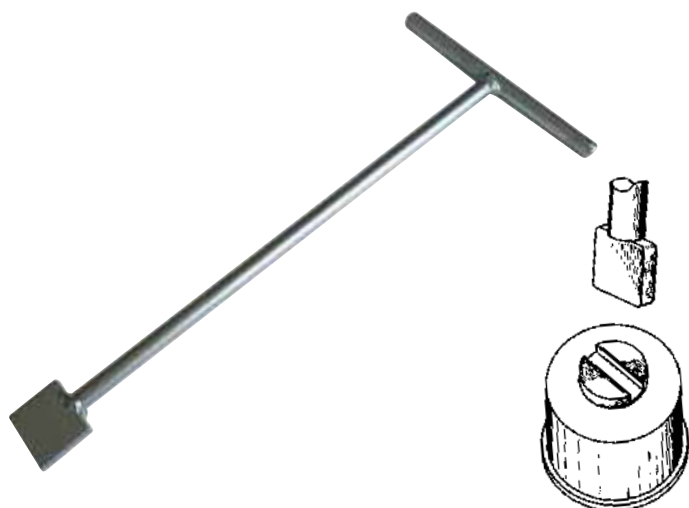

**Art. 5048**

**PINZA PER ANELLI SEEGER INTERNI CON BECCUCCI A 90° PER FORI PROFONDI**

**INTERNAL CIRCLIP PLIERS WITH 90° LONG TIP FOR DEEP HOLE AREA**



## Art. 5049

**PINZA COMPONIBILE PER SEEGER INTERNI E ESTERNI  
COMPLETA DI 4 PUNTALI**

**COMBINATION INTERNAL/EXTERNAL CIRCLIP PLIER SET  
COMPLETE WITH 4 JAWS**

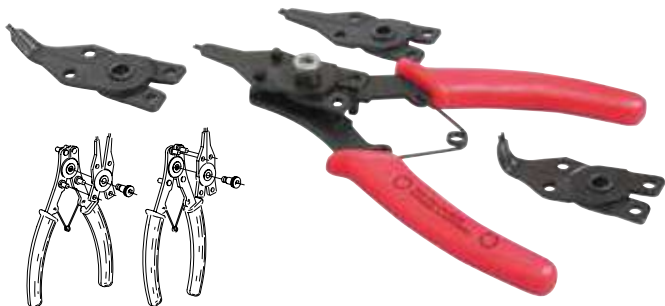

INTERNAL EXTERNAL

## Art. 5090

**COPPIA ATTREZZI PER LAPPATURA SEDI VALVOLA  
DI Ø 16, 21, 25, 28 MM IN NEOPRENE**

**COUPLE OF VALVE LAPPERS TOOL  
Ø 16, 21, 25, 28 MM -IN NEOPRENE**



## Art. 4910

**CACCIAVITE A PUNTA PIATTA ARROTONDATA  
LUNGHEZZA 90 mm**

**SCREWDRIVER WITH ROUND SLOTTED HEAD  
90 mm LENGHT**



## Art. 5414

**SET DI 2 PINZE IN NYLON  
PER TUBI BENZINA**

**FUEL HOSES CLAMP - 2 pcs  
NYLON PLIER SET**



## Art. 5089

**LAPPATORE OSCILLANTE / ROTANTE PER SMERIGLIATURA SEDI VALVOLA  
SEDI VALVOLE IN CATTIVA CONDIZIONE LIMITANO LA PERFORMANCE DEL  
MOTORE.**

MINORE POTENZA, DIFFICOLTA' NELL'AVVIAMENTO (STARTING) E PERDITE DI GAS SONO IL SINTOMO DEL DANNEGGIAMENTO DELLE SEDI VALVOLA.

L'ATTREZZO E' PROVVISORIO DI **DUE LAPPATORI DA 19mm E 23mm.** SI UTILIZZA CON UN TRAPANO ELETTRICO PORTATILE.

**OSCILLATING / ROTATING VALVE GRINDING TOOL FOR GOOD MAIN TENANCE OF VALVE SEATS**

BADLY SEATED VALVES REDUCE ENGINE PERFORMANCE. LOSS OF POWER, POOR STARTING, GAS ESCAPING ARE SYMPTOM OF SEATED VALVES DAMAGE.

THE TOOL IS EQUIPPED WITH **TWO SUCKER HEADS OF 19 AND 23mm.** USABLE WITH A PORTABLE ELECTRIC DRILL



## Art. 4916

**CACCIAVITE EXTRALUNGO A PUNTA PIATTA DI 4 mm  
LUNGHEZZA 300 mm**

**EXTRA LONG SCREWDRIVER WITH 4 mm SLOTTED HEAD  
300 mm LENGHT**

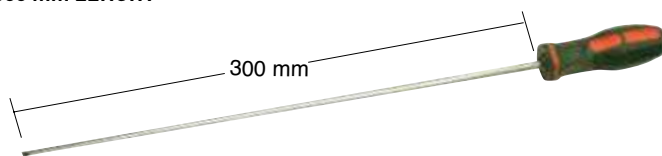

## Art. 4919

**CACCIAVITE PER LA REGOLAZIONE DEI CARBURATORI CON TESTA VITE A "D" DI 4,1 mm**

**4,1 mm D-TYPE SOCKET DRIVER FOR CARBURETTORS ADJUSTMENT**

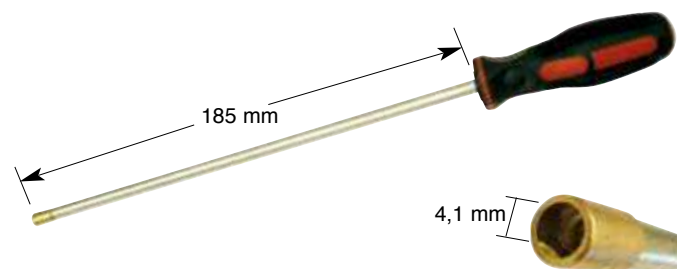

## Art. 5088

**COPPIA LAPPATORI DI RICAMBIO DA 19 mm E 23 mm PER ART. 5089**

**COUPLE OF 19 / 23 mm SPARE PARTS SUCKER HEADS FOR ART. 5089**



**CACCIAVITI A PERCUSSIONE CON TORSIONE DESTRA O SINISTRA - UTILI PER SBLOCCARE VITI OSSIDATE E PER UN FORTE SERRAGGIO**

**IMPACT SCREWDRIVERS WITH RIGHT OR LEFT DRIVING DIRECTION - USEFUL FOR LOOSENING RUSTED SCREWS AND HEAVY-LOCKING**

**Art. 4917**

**CACCIAVITE MANUALE A PERCUSSIONE**

PER VITI CON TESTA A CROCE; LINEARE; ESAGONALE DA 6 E 8 mm.

**IMPACT SCREWDRIVER**

FOR CROSS HEAD SCREWS; SLOTTED; AND 6 - 8 mm HEXAGON.

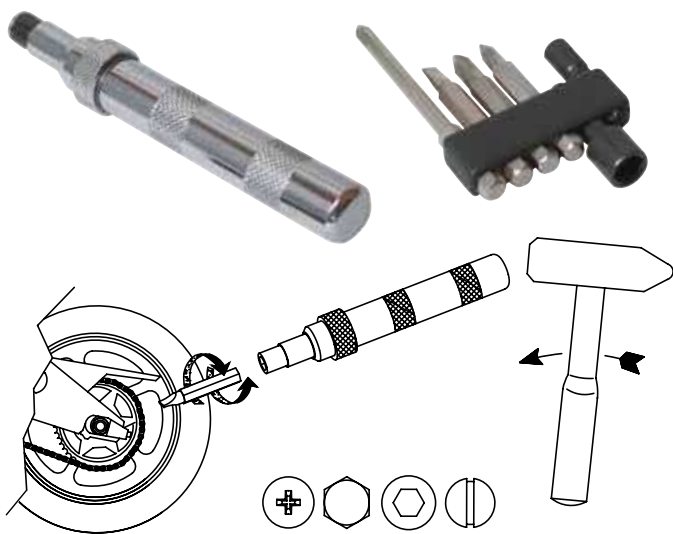

**Art. 4918**

**CACCIAVITE MANUALE A PERCUSSIONE - TOP QUALITY**

CON PUNTE ESAGONALI DA 4 - 5 - 6 - 8mm

PUNTE TORX® DA T-40 T-45

PUNTE CRUCIFORMI PH 1 - 2 - 3

PUNTA CACCIAVITE DA 8

PUNTE CRUCIFORMI PH 2-3, LUNGHEZZA 80mm

IN ELEGANTE ASTUCCIO DI METALLO

**TOP QUALITY - IMPACT SCREWDRIVER**

CONTENTS :

HEX BITS 4 - 5 - 6 - 8mm

TORX® BITS T-40 T-45

CROSS HEAD BITS PH 1 - 2 - 3

FLAT BIT 8 mm

CROSS HEAD BITS PH 2-3 80mm LENGHT

PACKING: ELEGANT METAL BOX



**Art. 5118**

**CALIBRO PER CARBURATORI**

PER MISURARE IL LIVELLO DEL GALLEGGIANTE, IL CONTROLLO DELLA SUPERFICIE DELLE GUARNIZIONI DEL GALLEGGIANTE E DEL CARBURATORE

**CARBURETOR'S GAUGE**

USEFUL TO GAUGE THE FLOAT LEVEL, TO CHECK THE GASKET FLOAT AND CARBURETOR'S SURFACE



**Art. 5115**

**KIT PER RIPARAZIONE CARBURATORI CON TESTA DI ROTAZIONE A 90°, COMPLETO DI 7 ATTREZZI**

**CARBURETOR ADJUSTING SET WITH 90° ROTATION HEAD, COMPLETE OF 7 TOOLS**



**Art. 5113**

**ATTREZZO REGOLAZIONE VITI SUL CARBURATORE**

LUNGHEZZA TESTA 25mm PIEGATA A 110°

LUNGHEZZA TOTALE 430mm - CACCIAVITE ROTANTE

**ADJUSTING TOOL FOR CARBURETOR SCREWS**

HEAD LENGHT 25mm, 110° ANGLED

TOTAL LENGHT 430mm - ROTATING SCREWDRIVER



**Art. 0586**

**ATTREZZO PER MISURARE E PULIRE GLI UGELLI DEI CARBURATORI**

CON 20 MISURATORI DA 0,45 A 1,5 mm

**CARBURETORS NOZZLE MEASURING AND CLEANING TOOL SET**

WITH 20 SIZES FROM 0,45 TO 1,5 mm





## Art. 4913

**SET DI PUNTE CONICHE PER SVITARE VITI CON TESTA DANNEGGIATA**  
8 PZ DA 3mm A 12mm

LA CARATTERISTICA DELLA PUNTA E' DI ESSERE AUTOGRIPPANTE  
NON USARE AVVITATORI AD ARIA  
IL PARTICOLARE E' PROTETTO DA BREVETTO

**SET OF CONICAL POINTS TO REMOVE DAMAGED HEAD SCREWS**

8 PCS FROM 3mm TO 12mm  
SELFSEIZING POINT - DON'T USE AIR SCREWDRIVER  
TOOL PATENTED



## Art. 5418

**SET DI CHIAVI SNODATE PER GHIERE A SETTORE IN ACCIAIO AL CROMO VANADIO CON NASELLO TONDO Ø 4 - Ø 5 - Ø 6 - Ø 7,9 mm E NASELLO QUADRO DI 5 - 10 - 12 mm**  
CAPACITÀ: Ø 35/60 - Ø 60/90 - Ø 90/120 mm

**ADJUSTABLE WRENCHES SET FOR RING SECTORS IN CHROME VANADIUM STEEL WITH ROUND PIN Ø 4 - Ø 5 - Ø 6 - Ø 7,9 mm AND SQUARE PIN OF 5 - 10 - 12 mm**  
CAPACITY: Ø 35/60 - Ø 60/90 - Ø 90/120 mm



## Art. 5140

**NEW**

**ATTORCIGLIATRICE PER FILO DI SICUREZZA**  
LUNGHEZZA MM. 215

IL FILO ATTORCICLIATO SI MODELLA CON FACILITA' E SENZA DANNI CON LA STESSA PINZA.  
UTILE PER EVITARE LO SVITAMENTO DI DADI E BULLONI.

**SAFETY WIRE TWISTER PLIER**

LENGHT MM. 215

THE TWISTED WIRE IS EASY TO MOULD WITHOUT DAMAGE WITH THE SAME PLIER.  
DESIGNED TO PREVENT NUTS/BOLTS FROM GETTING UNFASTED.

DISPONIBILE DA APRILE 2023

AVAILABLE FROM APRIL 2023



## Art. 0600

**INSTALLATORI PER PRIGIONIERI**

SET DI 3 PEZZI DA M6x1 - M8x1,25 - M10x1,25

**STUD INSTALLATION TOOLS**

SET OF 3 PIECES SIZE M6x1 - M8x1,25 - M10x1,25



## Art. 0605

**NEW**

**SET DI ATTREZZI PER SMONTARE E RIMONTARE I PRIGIONIERI**

CON INNesti M6 - M8 - M10 - M12  
E CHIAVE A CRICCHETTO MM. 14 x 17

**STUD REMOVER & INSTALLER SET**

WITH 4 PCS SIZE M6 - M8 - M10 - M12  
AND GEAR WRENCH MM. 14 x 17



## Art. 5415

**CHIAVE REGOLABILE PER GHIERE A SETTORE**  
CAPACITÀ DA Ø 25 mm A Ø 70 mm

**ADJUSTABLE LOCKING RING SECTOR**  
TOOL FROM Ø 25 mm TO Ø 70 mm

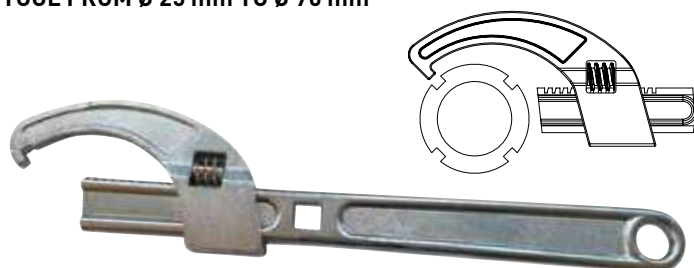

## Art. 5099

**ATTREZZO UNIVERSALE COMPRIMI MOLLE - VALVOLE**  
CON 5 ADATTATORI DA 16 - 19 - 23 - 25 - 30 MM, 3 VITI DI  
COMPRESSIONE DA 50-90-110 MM DI LUNGHEZZA

**UNIVERSAL VALVE SPRING COMPRESSOR TOOL**  
WITH 5 COLLECT ADAPTORS 16 - 19 - 23 - 25 - 30 MM, 3  
COMPRESSOR'S SCREWS OF 50-90-110 MM LENGHT



Max. Opening: 175mm Max. Depth: 125mm

## Art. 5100

**ATTREZZO UNIVERSALE (MAXI) COMPRIMI MOLLE - VALVOLE**  
CON 5 ADATTATORI DA 16, 19, 23, 25, 30 MM, 3 VITI DI COMPRESSIONE  
DA 60, 100, 100 MM DI LUNGHEZZA

**(MAXI) UNIVERSAL VALVE SPRING COMPRESSOR TOOL**  
WITH 5 COLLECT ADAPTORS 16, 19, 23, 25, 30 mm, 3 COMPRESSOR'S  
SCREWS OF 60, 100, 100 mm LENGHT



Max. Opening: 230mm Max. Depth: 130mm

## Art. 5662

**ATTREZZO PER METTERE IN CARICA LA**  
**MOLLA DEL SETTORE AVVIAMENTO**

**TOOL TO REASSEMBLE THE START SHAFT**  
**SPRING**

**PER / FOR KYMCO-PEUGEOT**

**TUTTI I MODELLI 2t-4t DA 50 A 125**

**ALL MODELS 2s-4s FROM 50 TO 125**



## Art. 5670

**ATTREZZO PER METTERE IN CARICA LA**  
**MOLLA DEL SETTORE AVVIAMENTO**

**TOOL TO REASSEMBLE THE START SHAFT**  
**SPRING**

**PER MOTORI / FOR ENGINES**

**PEUGEOT TWEET 50/125/150**

**SYM 125/150 4t - SYMPHONY**

**E ALTRI / AND OTHERS**



## Art. 5040

**ATTREZZO COMPRESSIONE FASCE ELASTICHE**  
PER PISTONI Ø DA 40 A 80 mm

**SMALL ENGINE PISTON RING COMPRESSOR**  
FOR PISTONS FROM Ø 40 TO 80 mm



## Art. 5042

**PINZA PER TOGLIERE L'ANELLO DI TENUTA DELLO SPINOTTO DEL PISTONE**  
CON UN BECCO DENTELLATO E UN BECCO A PUNTA SCANALATA

**PISTON RING REMOVER PLIER**

WITH CROSSED AND GROOVED HEAD

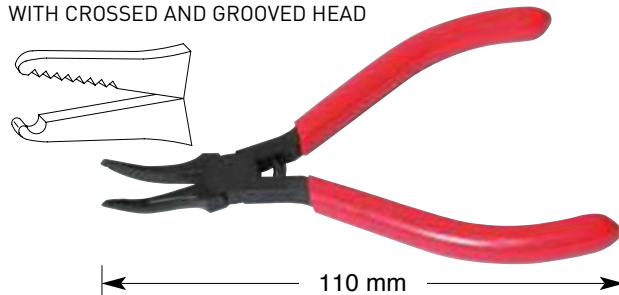

## Art. 5044

**ATTREZZO PER FACILITARE L'INSERIMENTO DEL PISTONE NEL**  
**CILINDRO SERRANDO LE FASCE ELASTICHE**  
CAPACITA' DA Ø 40 A 85 mm

**PISTON RING TOOL IT MAKES EASIER THE INSTALLATION OF PISTON**  
**INTO CYLINDER WITH PISTON RINGS COMPRESSION**

CAPACITY FROM Ø 40 TO 85 mm



## Art. 5045

**ATTREZZO ESPANSORE FASCE ELASTICHE PISTONI**  
ANELLI CON SPESSORE DA 1,2 A 6,3 mm

**PISTON RING EXPANDER TOOL**  
RING WIDTHS FROM 1,2 TO 6,3 mm

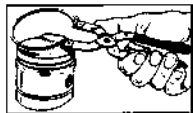

## Art. 5060

**ATTREZZO MONTAGGIO/SMONTAGGIO SPINOTTO PISTONE**  
PISTONE Ø 13, 15, 16, 19, 22 mm

**PISTON SPINDLE ASSEMBLING/DISASSEMBLING TOOL**  
TOOL Ø 13, 15, 16, 19, 22 mm



**ATTREZZO BLOCCA PISTONE**  
PISTON LOCKING TOOL

Conf. / Pack 1 pc

## Art. 4931

PER CANDELE / FOR SPARK PLUGS  
DA / FROM 14

## Art. 4932

PER CANDELE / FOR SPARK PLUGS  
DA / FROM 12

## Art. 4936

**M= 14 x 1,25**

**MICROMETRO PER LA MESSA A PUNTO DEL MOTORE**  
ISTRUZIONI NELLA CONFEZIONE

**ENGINE MICROMETER TIMING TOOL**  
USER INSTRUCTION INCLUDED

Conf. / Pack 1 pc

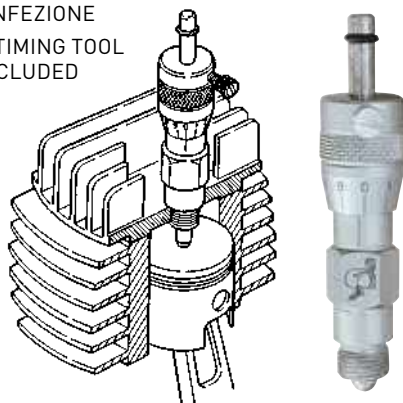

## Art. 0594

**GONIOMETRO ANGOLARE**

MISURA L'ANGOLO DI TORSIONE PER UN SERRAGGIO  
ALLINEATO DI DADI, VITI E BULLONI  
FOGLIO ISTRUZIONI NELLA CONFEZIONE

**ANGULAR TORQUE GAUGE**

ALLOWS OPERATOR TO ACCURATELY TIGHTEN NUTS,  
SCREWS AND BOLTS  
USER INSTRUCTIONS INCLUDED



## Art. 5121

**ATTREZZO REGOLAZIONE PUNTERIE MOTORI 4t**

SET COMPLETO DI 3 CHIAVI CON ESAGONO DA 8 - 9 - 10 mm CON MANICO;  
REGOLATORI CON INNESTO QUADRO DI 3 E 4 mm E INNESTO A TAGLIO

**4s ENGINES TAPPET ADJUSTING TOOL SET**

SET CONTAINS 3 HEXAGONAL WRENCHES OF 8 - 9 - 10 mm WITH HANDLE;  
ADJUSTERS WITH SQUARE JOINT OF 3 AND 4 mm AND SLOT JOINT



## Art. 5120

**ATTREZZO REGOLAZIONE PUNTERIE PER MOTORE 4t CON 3**  
GUIDE ESAGONALI DI 8 - 9 - 10 mm

**TAPPET ADJUST TOOL FOR 4s ENGINE WITH 3 HEXAGONAL**  
GUIDES 8 - 9 - 10 mm



## Art. 5122

**ATTREZZO UNIVERSALE SMONTAGGIO**  
CHIAVELLE DELLE VALVOLE

PER MOTORE SCOOTER 4t

**VALVE COTTER UNIVERSAL TOOL**  
FOR SCOOTER 4s ENGINE



**Art. 5035**

**ATTREZZO PROFESSIONALE SMONTA CARTER MOTORE**  
PER MOLTI TIPI DI MONOCILINDRICI VERTICALI A 2 E 4 TEMPI  
CON 3 + 3 VITI DA 6 & 8 mm x 200

**PROFESSIONAL CRANKCASE SEPARATOR TOOL**  
FOR MOST 2 & 4 STROKE ENGINES WITH VERTICALLY SINGLE CYLINDERS  
EQUIPPED WITH 3 + 3 BOLTS OF 6 & 8 mm x 200



**Art. 5038**

**ATTREZZO UNIVERSALE PER SMONTARE IL SEMICARTER DEL MOTORE**  
DA 50 A 250cc.

**CRANK BOX TOOL TO DISASSEMBLE THE ENGINE HALF CARTER FROM**  
50 TO 250cc.



**Art. 5036**

**ATTREZZO PER IL MONTAGGIO DELL'ALBERO MOTORE NEL SEMICARTER**  
COMPLETO DI 2 INNESTI FILETTATI DA M10 x 1.25 E M12 x P1.25

**CRANK INSTALL TOOL FOR THE CRANKSHAFT ASSEMBLY INTO THE**  
HALF CARTER  
EQUIPPED WITH 2 M10 x 1.25 AND M12 x P 1.25 THREADED JOINTS



**Art. 5037**

**ATTREZZO PROFESSIONALE PER SMONTARE IL SEMICARTER DEL MOTORE**  
COMPLETO DI 3 VITI DA M8 E 3 PROLUNGHE DA M6  
CAPACITA' DI UTILIZZO DA 22 A 120 MM DALLA VITE CENTRALE.  
AMPIA GAMMA DI UTILIZZO

**HEAVY-DUTY CRANK CASE SEPARATOR TOOL**  
EQUIPPED WITH 3 M8 SCREWS AND 3 M6 EXTENSIONS  
USER CAPACITY FROM 22 TO 120 MM FROM THE CENTRE SCREW.  
WIDE RANGE OF USE

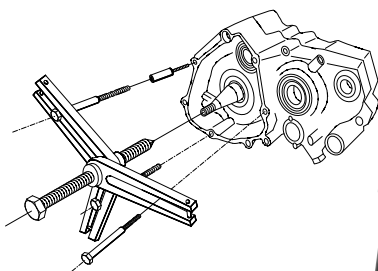

## Art. 5151

### SET GUIDA CUSCINETTI E BOCCOLE

UTILE PER RIMETTERLI CORRETTAMENTE NELLE LORO SEDI  
CON 6 GUIDE IN ALLUMINIO DA  $\varnothing$  40 mm. A 65 mm.

### BUSHING/BEARINGS DRIVER SET

USEFUL TO PLACE THEM CORRECTLY INTO THEIR SEATS  
WITH 6 ALUMINIUM SLIDES FROM  $\varnothing$  40 mm. TO 65 mm.



## Art. 5030

**SERIE ESTRATTORI PER CUSCINETTI CARTER MOTORE** completa di asta con battente. Estrattori per interno motore da  $\varnothing$  8, 10, 12, 15, 17, 20, 25, 30 mm e per silent-block da 20x17, 30x28 mm

**ENGINE CARTER BEARINGS PULLER TOOL** complete with sliding sledgehammer. Inner engine puller from  $\varnothing$  8, 10, 12, 15, 17, 20, 25, 30 mm and for silent-block from 20x17, 30x28 mm



**ESTRATTORI DI RICAMBIO PER ART. 5030**  
**SPARE PARTS PULLERS FOR ART.5030**

Art. 5000  $\varnothing$  8 mm

Art. 5009  $\varnothing$  17 mm

Art. 5002  $\varnothing$  10 mm

Art. 5012  $\varnothing$  20 mm

Art. 5004  $\varnothing$  12 mm

Art. 5017  $\varnothing$  25 mm

Art. 5007  $\varnothing$  15 mm

Art. 5022  $\varnothing$  30 mm



**ESTRATTORI DI RICAMBIO PER ART. 5030 PER SILENT-BLOCK**  
**SPARE PARTS PULLERS FOR ART.5030 FOR SILENT-BLOCK**

Art. 5024 20 x 17 mm

Art. 5027 30 x 28 mm

## Art. 5028

**SET DI 6 ATTREZZI PER SMONTARE E RIMONTARE I CUSCINETTI DELLE RUOTE**  
CON ESPANSORI  $\varnothing$  10 - 12 - 15 - 17 - 20 - 25 mm

**6 pcs WHEEL BEARING REMOVER AND INSTALLER SET**  
WITH 10 - 12 - 15 - 17 - 20 - 25 mm COLLETS



## Art. 5032

**SERIE DI ESTRATTORI PER CUSCINETTI NEL CARTER**

Capacità 8-25 mm (7 attrezzi leva cuscinetto).  
Regolazione larghezza zampe da 26 a 66 mm

**BLIND HOLE BEARINGS PULLER SET**  
Capacity 8-25 mm (7 bearing puller tools).  
Width leg capacity from 26 to 66 mm

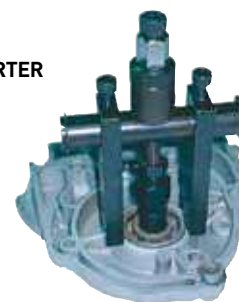

## Art. 5068

**ATTREZZO PER LO SMONTAGGIO DEL CUSCINETTO SULL'ALBERO MOTORE** PARTICOLARMENTE ADATTO QUANDO IL CUSCINETTO E' ADERENTE ALLA FIANCATA COME SUI MOTORI PIAGGIO  
CAPACITA' DA  $\varnothing$  28 A  $\varnothing$  75 mm  
LA FINITURA DELL'ATTREZZO E' CROMATA E I 2 GUSCI SONO IN ACCIAIO DI ALTA QUALITA'  
CONFEZIONATO IN ASTUCCIO DI METALLO

**CRANK BEARING PULLER TOOL** PARTICULARLY SUITABLE WHEN THE BEARING IS STICKING TO THE SIDE AS FOR PIAGGIO ENGINES  
CAPACITY FROM  $\varnothing$  28 TO  $\varnothing$  75 mm  
TOOL CHROME FINISHED AND 2 SHELLS IN HIGH QUALITY STEEL - SUPPLIED IN METAL BOX

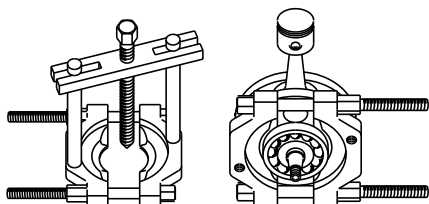

## Art. 5070

**ATTREZZO SMONTAGGIO CUSCINETTO ALBERO MOTORE**  
CON GUSCI PER CUSINETTI DA  $\varnothing$  30 A  $\varnothing$  50mm  
E GUSCI PER CUSINETTI DA  $\varnothing$  50 A  $\varnothing$  75mm  
BRACCI DA 60mm A 190mm

**UNIVERSAL CRANK BEARINGS PULLER TOOL**  
WITH SHELLS FOR BEARINGS FROM  $\varnothing$  30 TO  $\varnothing$  50mm AND SHELLS FOR BEARINGS FROM  $\varnothing$  50 TO  $\varnothing$  75mm  
ARMS FROM 60mm TO 190mm



## Art. 5033

**ESTRATTORE A 3 GRIFFE PER TOGLIERE I CUSCINETTI FACENDO PRESA SULL'ANELLO INTERNO**

CAPACITA':  
DA  $\varnothing$  INTERNO 13mm  
A  $\varnothing$  38mm

**3 JAWS PILOT BEARINGS PULLER TOOL TO GRASP THE INTERNAL RING**

CAPACITY:  
FROM INTERNAL  $\varnothing$  13mm  
TO  $\varnothing$  38mm

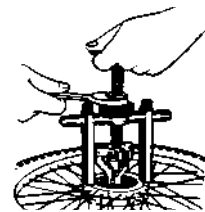

## Art. 5034

**ESTRATTORE PER INGRANAGGI E CUSCINETTI DI PICCOLO DIAMETRO ( DA 19 A 45 mm )**

**MICRO GEAR AND BEARING PULLER TOOL ( SPREAD FROM 19 TO 45 mm )**



## Art. 5058

**ATTREZZO PER TOGLIERE GLI ANELLI DEI CUSCINETTI DAL CANNOTTO DELLO STERZO**

CAPACITA' DA  $\varnothing$  30mm A 68mm  
INSERIRE L'ATTREZZO NEL CANNOTTO E ALLARGARE I DUE BRACCI CON LA VITE. DAL LATO OPPOSTO, USANDO UNO SPEZZONE DI LEGNO O ALLUMINIO, BATTERE PER ESPELLERE IL CUSCINETTO.

**STEERING STEM BEARING REMOVAL TOOL**

CAPACITY FROM  $\varnothing$  30mm TO 68mm  
INSERT IT INTO THE STEM AND OPEN THE TWO ARMS WITH THE SCREW. ON THE OTHER SIDE, USING A WOODEN OR ALUMINIUM BAR PUT THE BEARING THROUGH.

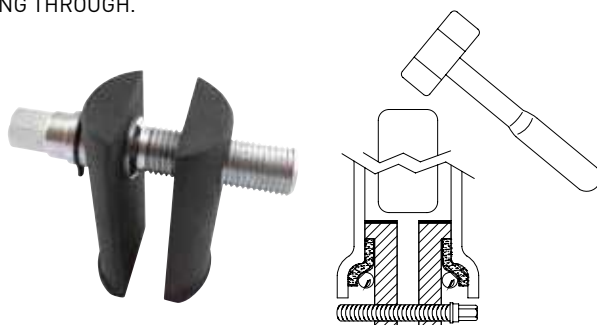

**Art. 5054**

**ATTREZZO PIANTAGGIO CUSCINETTI CONICI SUL PIANTONE**  
IL TUBO DI GUIDA E' COMPLETO DI 3 RIDUZIONI PER CUSCINETTI DI Ø INTERNO 25/26/28/29/30 (1", 1-1/8" E 1-3/8")

**STEERING TUBE BEARING INSTALLER ON THE FORK HEAD**  
THE GUIDE TUBE IS EQUIPPED WITH 3 BEARINGS REDUCTIONS OF INTERNAL Ø 25/26/28/29/30 (1", 1-1/8" AND 1-3/8")

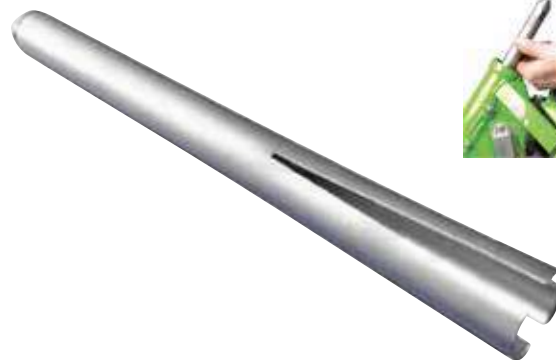

**ATTREZZI CON TERMINALE A ESPANSIONE PER ESTRARRE LE CALOTTE DAL TUBO DI STERZO**

IN ACCIAIO Cr-Mo

**TOOLS WITH EXPANSION END TO TAKE OUT THE BEARING CUPS FROM THE STEERING TUBE**

IN Cr-Mo STEEL

**Art. 5051**

CAPACITA' DA Ø 26mm A Ø 35mm  
CAPACITY FROM Ø 26mm TO Ø 35mm

**Art. 5053**

CAPACITA' DA Ø 35mm A Ø 55mm  
CAPACITY FROM Ø 35mm TO Ø 55mm

## ATTREZZI PER BLOCCARE LA ROTAZIONE DELLA PULEGGIA ANTERIORE FRONT PULLEY LOCKING TOOL - PREVENT PULLEY ROTATION



Art. 5425

PER MOTORI / FOR ENGINES  
**PIAGGIO 50/125 cc 2t-4t**



Art. 5430

PER MOTORI / FOR ENGINES  
**PIAGGIO 125-150cc 4t**

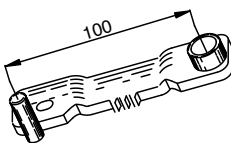
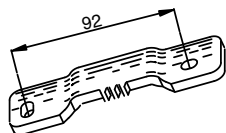

Art. 5458

PER MOTORI / FOR ENGINES  
**PEUGEOT KISBEE 50cc 4t**  
CON DISTANZIALE E BULLONCINO  
WITH SPACER AND SMALL BOLT

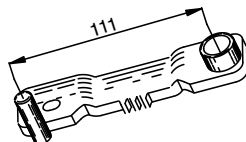

Art. 5468

PER MOTORI / FOR ENGINES  
**PEUGEOT 50/100cc 2t**

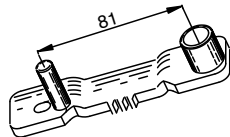

Art. 5580

PER MOTORI / FOR ENGINES  
**KYMCO 50cc 2t**

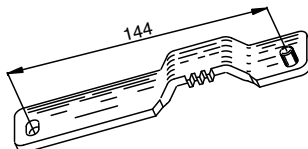

Art. 5582

PER MOTORI / FOR ENGINES  
**KYMCO AGILITY 50 cc 4t**

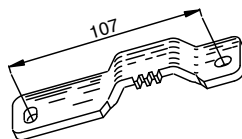

Art. 5454

PER MOTORI **SCOOTER 50cc 2t** DI FABBRICAZIONE  
CINESE (MODELLO QJ)  
FOR **50cc 2s** CHINESE **SCOOTER** ENGINES (QJ MODEL)  
MALAGUTI 50 AIR - CPI - KEEWAY - GENERIC  
e altri / and others

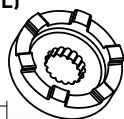

Art. 5497



Art. 5496

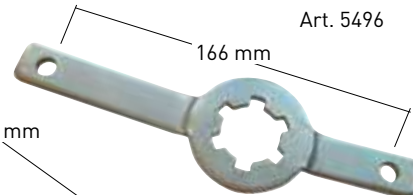

Art. 5496

MOTORI / ENGINES  
**YAMAHA-MINARELLI 50cc 2t**  
CILINDRO ORIZZONTALE / HORIZONTAL CYLINDER

Art. 5497

MOTORI / ENGINES  
**YAMAHA-MINARELLI 50cc 2t**  
CILINDRO VERTICALE / VERTICAL CYLINDER

Art. 5437

MOTORI / ENGINES 4t 3V  
**VESPA PRIMAVERA 125-150cc**  
**VESPA SPRINT 125 - 150cc**  
**PIAGGIO LIBERTY 125 - 150cc**

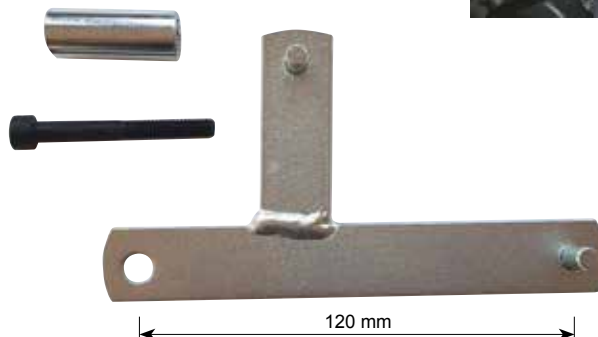

Art. 5440

PER MOTORI / FOR ENGINES  
**PIAGGIO 125/150 4t 3V**





## ATTREZZI PER BLOCCARE LA ROTAZIONE DELLA PULEGGIA ANTERIORE FRONT PULLEY LOCKING TOOL - PREVENT PULLEY ROTATION

### Art. 5442

PER MOTORI / FOR ENGINES  
**PIAGGIO 250-300cc 4t**  
**LC - GTS - GTV / QUASAR**  
**APRILIA SPORT CITY 300cc 4t**



### Art. 5509

PER MOTORI / FOR ENGINES  
**SYM 50cc 4t - FIDDLE - SYMPHONY**  
**PEUGEOT TWEET 50cc**



### Art. 5446

PER MOTORI **PIAGGIO 400-500cc 4t**  
FOR **PIAGGIO 400-500cc 4s** ENGINES

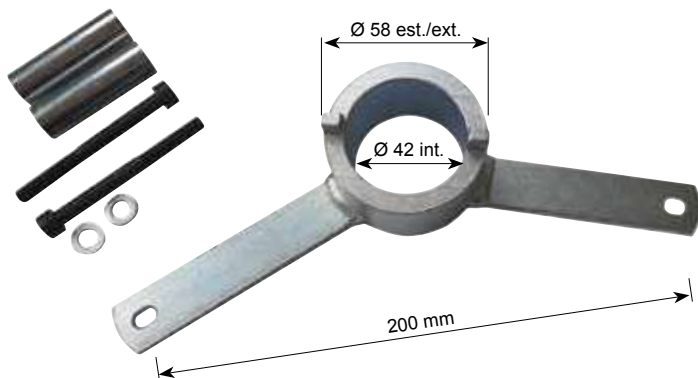

### Art. 5554

PER MOTORI / FOR ENGINES  
**HONDA - HONDA SH 125/150**  
**KYMCO - KEEWAY**  
**CPI/GENERIC 6 MARCE / 6 GEARS**  
**Scooter 50/125/150/300 2t-4t**

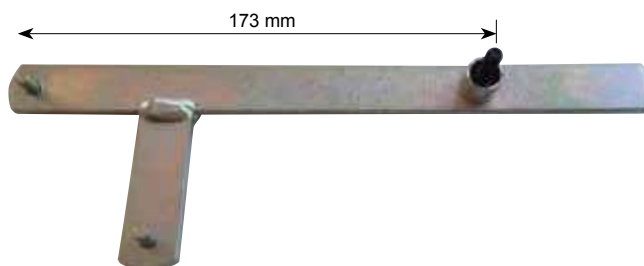

### Art. 5462

PER MOTORI **SUZUKI 125/150cc 4t**  
FOR **SUZUKI 125/150cc 4s** ENGINES  
**SCOOTER SIXTEEN**

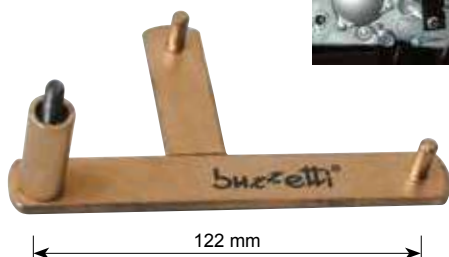

### Art. 5702

PER MOTORI / FOR ENGINES  
**LML STAR 125/150/151/200 4t**

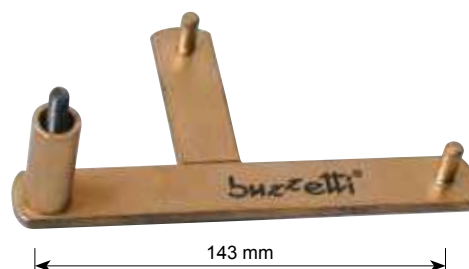

## ATTREZZO BLOCCA VOLANO MAGNETICO TOOL TO LOCK THE MAGNETIC FLY-WHEEL

### Art. 5516

PER MOTORI / FOR ENGINES  
**YAMAHA XENTER 125 / 150cc 4t**

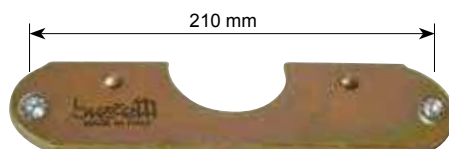

### Art. 5504

**YAMAHA - MINARELLI 50/100 2t**  
**PEUGEOT 50 2t**



## ATTREZZI PER IL BLOCCAGGIO DELLA ROTAZIONE DELLA CAMPANA FRIZIONE, DELLA PULEGGIA ANTERIORE E DEL VOLANO CLUTCH PULLEY, FRONT PULLEY AND FLYWHEEL LOCKING TOOL



### Art. 5636

**ATTREZZO CON DENTELLI PIATTI E DENTELLI TONDI DA Ø 8MM CON BLOCCAGGIO DELL'APERTURA**

CAPACITA' MAX. 130mm  
PESO 0,750 KG

**HOLDING TOOL WITH FLAT NOTCHES AND CIRCULAR TEETH OF Ø 8mm**

130mm MAX. CAPACITY  
WEIGHT 0,750 KG

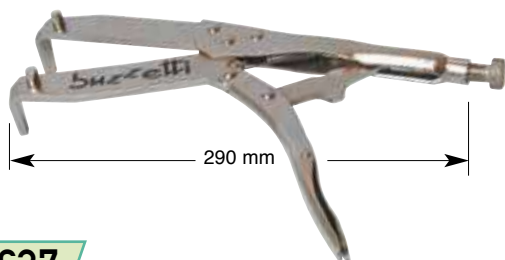

### Art. 5637

**ATTREZZO UNIVERSALE CON DENTELLI DA Ø 5mm E Ø 9mm**

CAPACITA' MAX. 140mm  
PESO 0,485 KG

**UNIVERSAL TOOL WITH Ø 5mm AND Ø 9mm NOTCHES**

140mm MAX. CAPACITY  
WEIGHT 0,485 KG

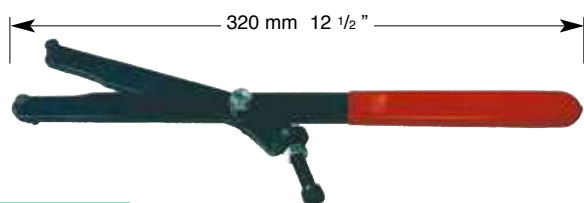

### Art. 5638

**ATTREZZO CON DENTELLI A SMUSSO PER BLOCCARE LA ROTAZIONE DI CORPI DENTATI**

CAPACITA' MAX. 125 mm  
PESO 0,620 KG

**TOOL WITH BLUNTED NOTCHES TO LOCK THE ROTATION OF TOOTHED PARTS**

125 mm MAX. CAPACITY  
WEIGHT 0,620 KG

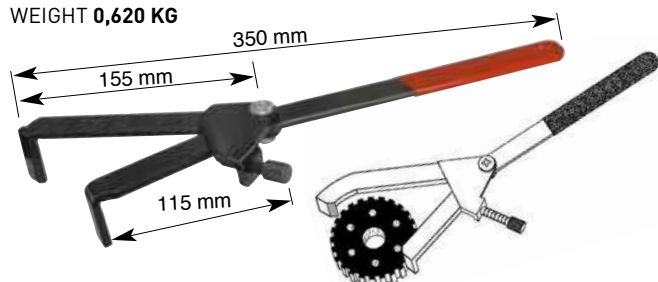

### Art. 5528

PER / FOR

**YAMAHA TMAX 500 - 530**

**ATTREZZO CON 4 PIOLI PER BLOCCARE LA PULEGGIA POSTERIORE E 2 PIOLI PER LA PULEGGIA ANTERIORE**

PESO 1 KG

**TOOL WITH 4 PINS TO LOCK THE REAR PULLEY AND 2 PINS FOR THE FRONT PULLEY**

WEIGHT 1 KG



### Art. 0312

**ATTREZZO PER LA REGOLAZIONE DELLA TENSIONE DELLE CINGHIE DENTATE**

VEDERE PAG. 60

ISTRUZIONI CON L'ATTREZZO

**TENSIONING GAUGE TOOL FOR TIMING BELTS**

SEE PAGE 60

USER INSTRUCTIONS INCLUDED

per / for **YAMAHA TMAX 530**



### Art. 5428

**ATTREZZO BLOCCA FRIZIONE**

per **PIAGGIO 125-250-300cc 4t**

**CLUTCH LOCKING TOOL**

for **PIAGGIO 125-250-300cc 4s**

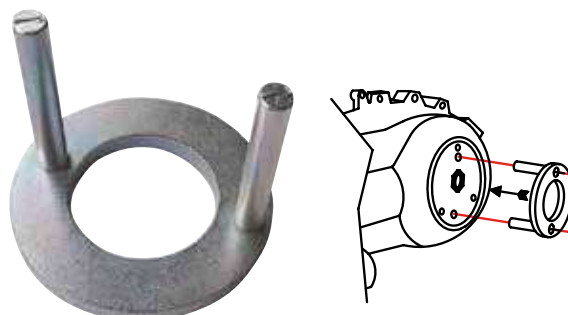

## Art. 5633

ATTREZZO UNIVERSALE PER IL BLOCCAGGIO DELLA ROTAZIONE DELLA CAMPANA FRIZIONE PER SCOOTER DA 125cc A 500cc  
CAPACITA' DA Ø 100 A Ø 255 mm  
UNIVERSAL TOOL TO HOLD CLUTCH PULLEY ROTATION FOR SCOOTER FROM 125cc TO 500cc  
CAPACITY FROM Ø 100 TO Ø 255 mm



## Art. 5635

ATTREZZO UNIVERSALE PER IL BLOCCAGGIO DELLA ROTAZIONE DELLA CAMPANA FRIZIONE DA 50cc A 125cc  
CAPACITA' DA Ø 45 A Ø 120mm  
UNIVERSAL TOOL TO HOLD CLUTCH PULLEY ROTATION FROM 50cc TO 125cc  
CAPACITY FROM Ø 45 TO Ø 120mm



ATTREZZO BLOCCA FRIZIONE  
CON ESAGONO  
TOOL TO LOCK THE CLUTCH  
WITH HEXAGON



## Art. 5427

PIAGGIO - VESPA - GILERA  
APRILIA - 50 2t-4t  
TUTTI I MODELLI / ALL MODELS  
ES./HEX. mm. 34

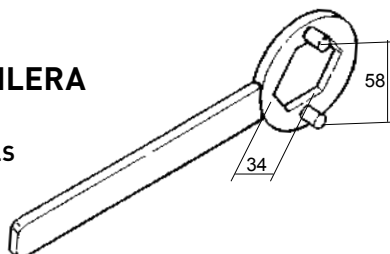

## Art. 5476

YAMAHA - MBK 50 2t  
MALAGUTI 50 2t - KYMCO 50 2t-4t  
PEUGEOT 50 2t  
SUZUKI 50 2t  
ES./HEX. mm. 39

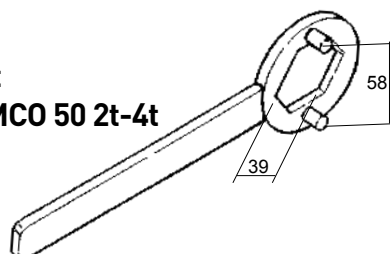

## Art. 5495

YAMAHA - MBK 50 2t  
MALAGUTI 50 2t - KYMCO 50 2t  
PEUGEOT 50 2t  
SUZUKI 50 2t  
ES./HEX. mm. 38

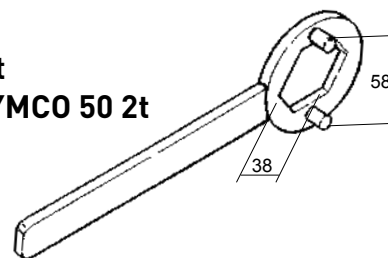

## Art. 5499

YAMAHA - MBK 50 2t  
MALAGUTI 50 2t - KYMCO 50 2t  
PEUGEOT 50 2t  
SUZUKI 50 2t  
ES./HEX. mm. 41

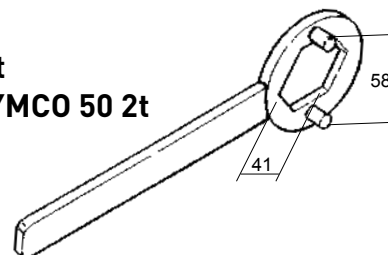

## Art. 5506

Per motori / for YAMAHA - MINARELLI engines  
scooter 125/150/200 4t  
YAMAHA XENTER 125/150  
ES./HEX. mm. 46

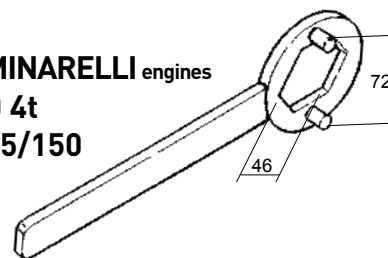

CHIAVE PER DADO VARIATORE POSTERIORE  
REAR VARIATOR NUT WRENCH

## Art. 5445

ES./HEX. mm. 46  
per/for PIAGGIO 250cc - YAMAHA 125-150cc

## Art. 5449

ES./HEX. mm. 55  
per/for PIAGGIO da/from 300cc a/to 500cc

**RITEGNO MOLLA FRIZIONE  
CLUTCH SPRING TOOL**

**Art. 5650**

**ATTREZZO RITEGNO MOLLA FRIZIONE PER MOTORI CON PULEGGIA Ø mm 125 MAX.**

**CLUTCH SPRING CHECK-TOOL FOR ENGINES WITH Ø mm 125 MAX PULLEY.**

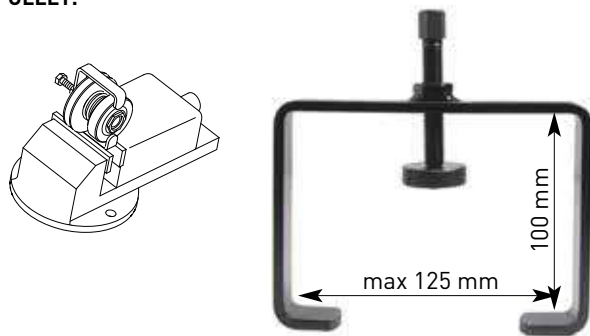

**Art. 5656**

**ATTREZZO RITEGNO MOLLA FRIZIONE PER MOTORI CON PULEGGE GRANDI  
CLUTCH SPRING CHECK-TOOL FOR ENGINES WITH BIG PULLEYS**

**CAPACITA' / CAPACITY 220mm**

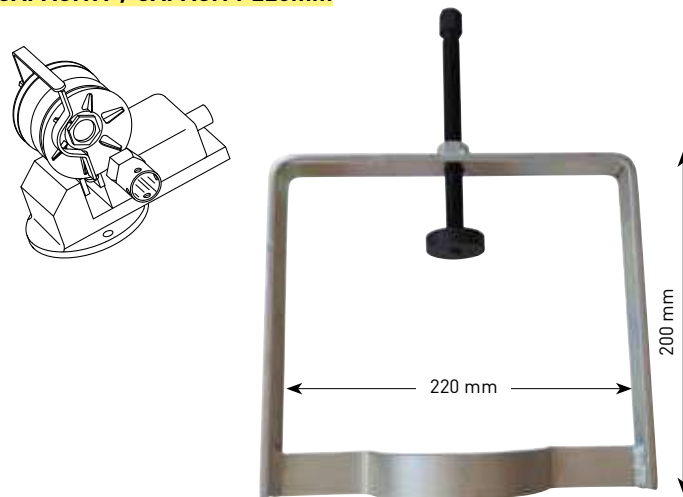

**Art. 5654**

**ATTREZZO RITEGNO MOLLA FRIZIONE PER MOTORI CON PULEGGIA Ø mm 155 MAX.**

**CLUTCH SPRING CHECK-TOOL FOR ENGINES WITH Ø mm 155 MAX PULLEY.**

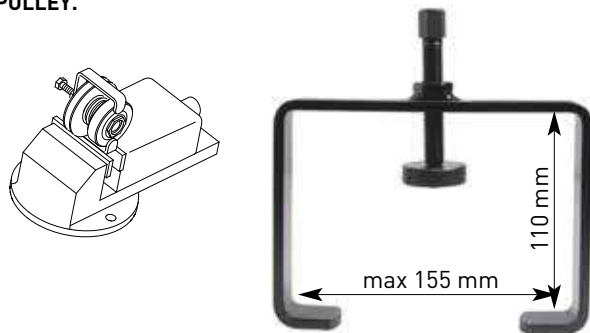

**Art. 5658**

**ATTREZZO RITEGNO MOLLA FRIZIONE  
CLUTCH SPRING CHECK TOOL**

**PER MOTORI / FOR ENGINES**

**PIAGGIO - VESPA**

**DA/FROM 125cc A/TO 500cc 4t**

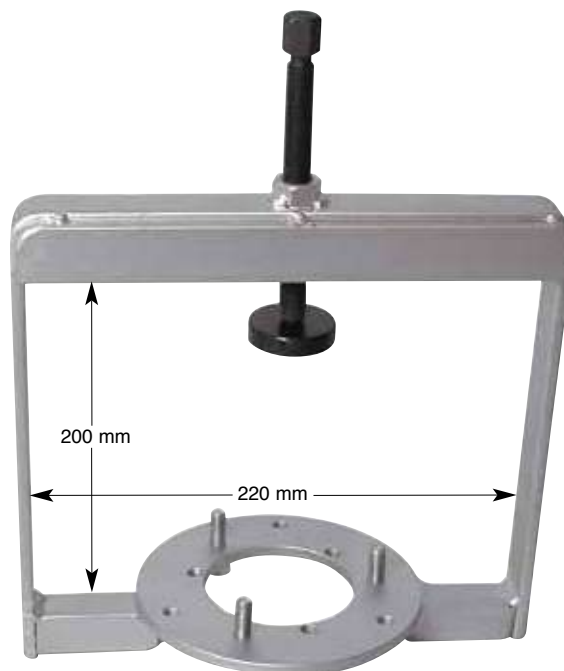

## ATTREZZI PER MANUTENZIONE CATENA MAINTENANCE CHAIN TOOLS

### Art. 4988

**ATTREZZO SMONTAGGIO/MONTAGGIO CATENE CON VITI A PUNTALE E PUNZONE RIVETTATORE.**

**COMPLETO DI VITE A PUNTA CONICA PER LA RIVETTATURA DEL PIOLO FORATO.**

PER CATENE RIF. 415-420-428-520-525-530-532.  
ISTRUZIONI D'USO NELLA CONFEZIONE.

**DISASSEMBLING/ASSEMBLING SEALED CHAINS TOOL WITH PUSH ROD SCREWS AND RIVETING PUNCH.**

**EQUIPPED WITH CONICAL POINT SCREW FOR DRILLED PIN RIVETING FOR CHAINS REF. 415-420-428-520-525-530-532.**

USER INSTRUCTIONS INCLUDED.



### Art. 4991

**COPPIA VITI DI RICAMBIO PER ART. 4992**

**COUPLE OF SPARES SCREWS FOR ART. 4992**

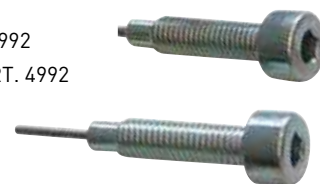

### Art. 4983

**SET 3 VITI DI RICAMBIO PER ART. 4988**

VITI DA M16 CON SPINA CORTA E CON SPINA LUNGA

VITE A PUNTA CONICA PER LA RIVETTATURA DEL PIOLO FORATO

**3 SPARES SCREWS FOR ART. 4988**

M16 SCREWS WITH SHORT AND LONG PIN

CONICAL POINT SCREW FOR OPENING CHAINS WITH DRILLED PIN



### Art. 4984

**PUNZONE RIVETTATORE DI RICAMBIO**

PER ART. 4988

**REPLACEMENT PUNCH RIVETING TOOL**

FOR ART. 4988



### Art. 4992

**ATTREZZO SMONTAGGIO/MONTAGGIO CATENA DI DISTRIBUZIONE**

ISTRUZIONI D'USO NELLA CONFEZIONE.

**ENGINE TIMING CHAIN DISASSEMBLING/ASSEMBLING TOOL**

USER INSTRUCTIONS INCLUDED.

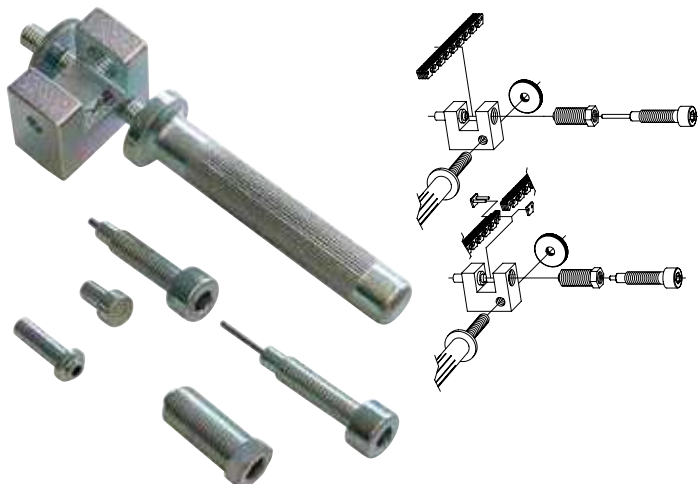

### Art. 4994

**ATTREZZO SMONTAGGIO/RIMONTAGGIO CATENE**

KIT PER CATENA DISTRIBUZIONE, CATENA CICLOMOTORE, CATENA MOTOCICLI.

CON PUNZONI ESPULSORI Ø 2,2 - 2,9 - 3,8 mm.

PUNZONE RIVETTATORE, GUIDAPUNZONI, ALLINEATORI PER CATENA E ACCESSORI DI MANOVRA.

ISTRUZIONI D'USO NELLA CONFEZIONE.

**CHAIN BREAKER AND RIVETING TOOL KIT**

KIT FOR ENGINE TIMING CHAIN, MOPED CHAIN, MOTORCYCLES CHAIN. WITH BREAKING TIPS Ø 2,2 - 2,9 - 3,8 mm.

RIVET TIP, TIP GUIDES, ALIGNMENTS BOLTS AND USER ACCESSORIES. USER INSTRUCTIONS INCLUDED.



## Art. 4995

**ROBUSTO ATTREZZO SMONTAGGIO/MONTAGGIO CATENE**  
PER CATENE RIF. 520-525-530.

**HEAVY-DUTY DISASSEMBLING/ASSEMBLING CHAINS TOOL KIT**  
FOR CHAINS REF. 520-525-530.



## Art. 4989

**ATTREZZO ROMPICATENA**  
PER CATENE RIF. 415, 420, 428, 520, 525, 530, 532  
ISTRUZIONI D'USO NELLA CONFEZIONE.

**CHAIN BREAKER TOOL**  
FOR CHAINS REF. 415, 420, 428, 520, 525, 530, 532  
USER INSTRUCTIONS INCLUDED.



## Art. 4990

**MINI PRESSA PER IL RIMONTAGGIO DELLE CATENE**  
MINI TOOL TO REASSEMBLE THE CHAINS

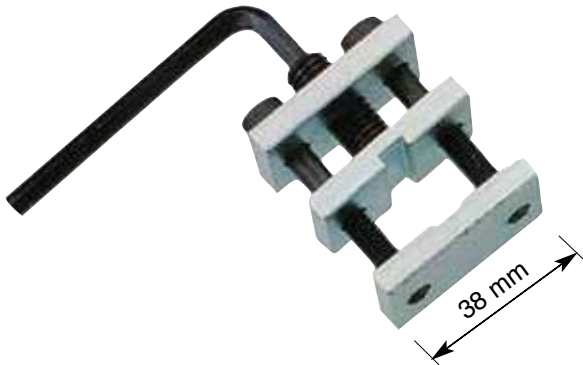

## Art. 4998

**SPAZZOLINO PULISCI CATENA**  
CON SPAZZOLE REGOLABILI  
**CHAIN CLEANER**  
WITH ADJUSTABLE BRUSHES

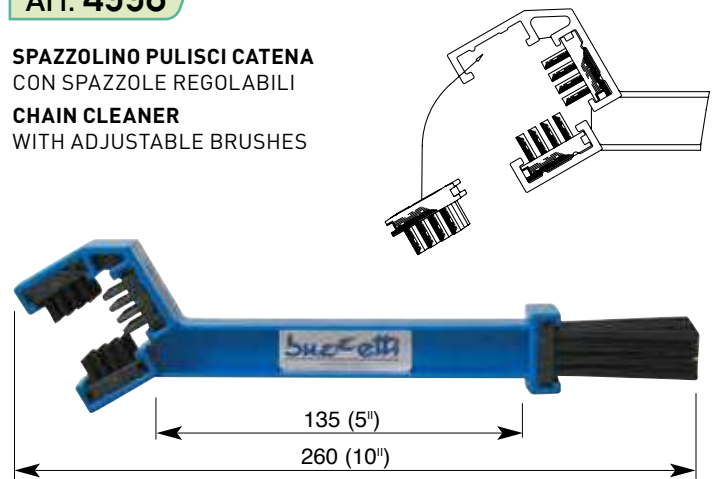

## ATTREZZI PER FRENI E FORCELLE TOOLS FOR BRAKES AND FORKS

### Art. 5125

#### ATTREZZO ALLARGA PINZA FRENO

BECCHI DA 42mm -  
APERTURA 48mm

#### OPEN BRAKE DISK TOOL -

42mm BEAKS - OPENING 48mm

A = da/from 120mm  
a/to 170mm

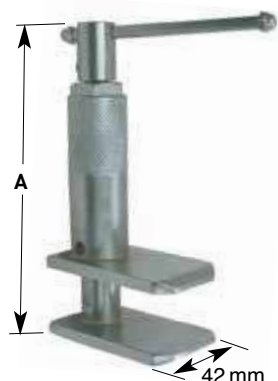

### Art. 5132

#### ATTREZZO CON ESPANSORI GRIPPANTI PER RIMUOVERE IL PISTONCINO DEL FRENO

CAPACITA' DA Ø 15 A Ø 28 mm

#### BRAKE PISTON REMOVAL TOOL

WITH SEIZENING EXPANDERS  
CAPACITY FROM Ø 15 TO Ø 28 mm



### Art. 5127

#### ATTREZZO ALLARGA PINZA FRENO

BECCHI DA 50mm  
APERTURA 70mm

#### OPEN BRAKE DISK TOOL

LENGHT NOSE 50mm  
OPENING 70mm



### Art. 9181

#### ATTREZZO A 4 ESAGONI PER BLOCCARE IL PERNO DELLA RUOTA ANTERIORE CON ESAGONO DA 17 - 19 - 22 - 24 MM

#### 4 HEXAGONES TOOL FOR LOCKING THE FRONT WHEEL AXLE

WITH 17 - 19 - 22 - 24 MM HEXAGON



### Art. 5130

#### PINZA REGOLABILE PER STACCARE E RIMONTARE IL PISTONCINO DEL FRENO

CAPACITÀ; 30 - 33 mm  
LUNGHEZZA PINZA 240 mm

#### BRAKE PISTON ADJUSTABLE PLIER TO DETACH AND REPLACE THE BRAKE PISTON

CAPACITY: 30 - 33 mm  
PLIER LENGTH 240 mm

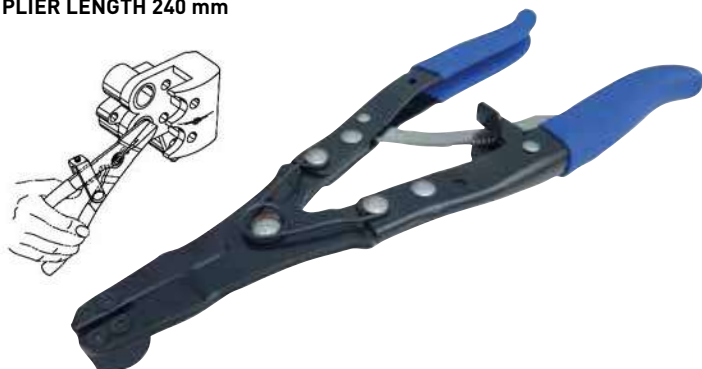

### Art. 9184

#### ATTREZZO A 6 ESAGONI PER BLOCCARE IL PERNO DELLA RUOTA ANTERIORE CON ESAGONI DA 12 - 14 - 17 - 19 - 22 - 24 MM

#### 6 HEXAGONES TOOL DESIGNED FOR LOCKING THE FRONT WHEEL AXLE

WITH 6 DIFFERENT SIZES 12 - 14 - 17 - 19 - 22 - 24 MM



### Art. 8996

#### ATTREZZO PER AGGANCIARE L'ASTA DELL'AMMORTIZZATORE DOPO L'INSTALLAZIONE DELLA MOLLA

CON ADATTATORI DA M10x1 ; M12x1 ; M12x1,25 ; M14x1  
ADATTO PER FORCELLE KAYABA - SHOWA - WP

#### DAMPING ROD TOOL TO RETRIEVE THE FORK'S ROD AFTER SPRING INSTALLATION

WITH M10x1 ; M12x1 ; M12x1,25 ; M14x1 ADAPTERS  
WORKS ON KAYABA - SHOWA - WP FORKS



**ATTREZZO BLOCCA POMPANTE FORCELLE IDRAULICHE  
DAMPER ROD LOCK TOOL FOR HYDRAULIC FORKS**

**Art. 9100**

PUNTALE A CROCE Ø DA 5 A 13 MM - LUNGHEZZA 340 MM  
CROSS HEAD POINT Ø FROM 5 TO 13 MM - LENGHT 340 MM

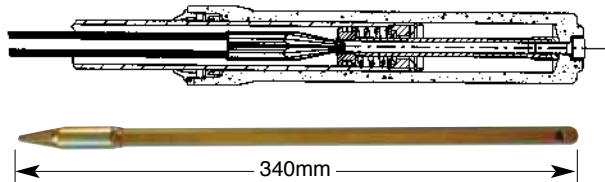

**Art. 9102**

PUNTALE A CROCE Ø DA 14 A 17 MM - LUNGHEZZA 600 MM  
CROSS HEAD POINT Ø FROM 14 TO 17 MM - LENGHT 600 MM

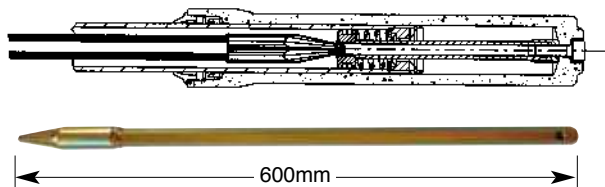

**ATTREZZI PER RIMUOVERE LE GUARNIZIONI  
SEAL PULLER TOOLS**

**Art. 9117**

PER / FOR  
Ø 20 - 60 mm



**Art. 9119**

PER / FOR  
Ø 20 - 90 mm



**Art. 9115**

ATTREZZO AUSILIARIO PER SMONTARE/RIMONTARE IL BRACCIO DELLE  
FORCELLE A STELI ROVESCIA TI  
ISTRUZIONI NELLA CONFEZIONE  
AUXILIARY UPSIDE DOWN FORKS ASSEMBLING/DISASSEMBLING TOOL  
USER INSTRUCTION INCLUDED



**Art. 4943**

SET DI 3 ATTREZZI PER RIMUOVERE GUARNIZIONI, O-RING,  
TUBI FLESSIBILI E ALTRO

SET OF 3 REMOVER TOOLS FOR SEAL, O-RINGS, FLEXIBLE  
HOSES AND OTHER



**Art. 5091**

SPURGATORE DELL'OLIO DEL SISTEMA FRENANTE  
ISTRUZIONI CON IL KIT  
BRAKE OIL BLEEDING DEVICE USER  
INSTRUCTION INSIDE THE PACKAGING





## Art. 5092

**MISURATORE LIVELLO OLIO DELLE FORCELLE**  
PER CONTROLLARE E RIPRISTINARE IL LIVELLO.  
UTILE PER LA RICARICA DELL'ESATTA QUANTITA' NECESSARIA.  
CAPACITÀ SIRINGA 70 cc  
ISTRUZIONI CON IL KIT.

**FORK OIL LEVEL GAUGE**  
TO CHECK AND GAUGE THE LEVEL.  
USEFUL TO REFILL THE CORRECT QUANTITY.  
SYRINGE CAPACITY 70 cc  
USER INSTRUCTION INSIDE THE PACKAGING.



## Art. 5094

**SET DI CHIAVI PER APRIRE / CHIUDERE LA VITE SPURGO FRENI**  
COMPLETO DI CHIAVI DA 8 - 10 - 11 MM  
TUBO IN SILICONE DA 1,2 mt CON VALVOLA DI SICUREZZA

**BRAKE BLEEDER WRENCH SET WITH CHECK VALVE FOR LOOSENING / TIGHTENING BLEED NIPPLES**

WITH 8 - 10 - 11 mm WRENCHES, 1,2 mt SILICON HOSE WITH SAFETY CHECK VALVE

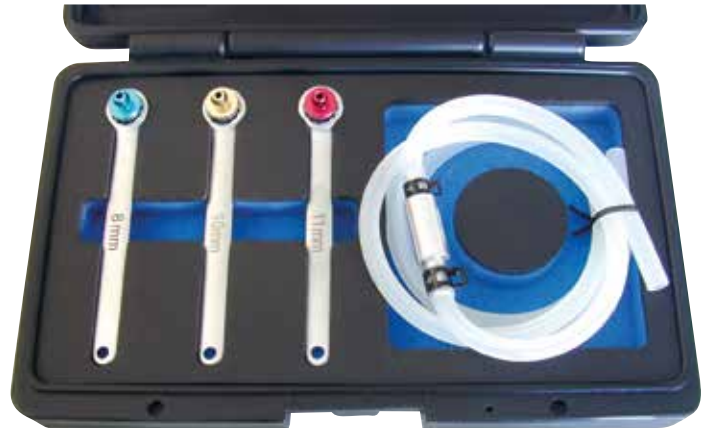

## Art. 5093

**ATTREZZO PER SCARICARE L'OLIO DEI FRENI**  
PER IL CAMBIO DELL'OLIO NELL'IMPIANTO FRENANTE. LA PARTICOLARE VALVOLA PERMETTE AL FLUIDO DI FUORIUSCIRE IMPEDENDO ALLE BOLLE D'ARIA DI ENTRARE NEL SISTEMA FRENANTE

**BRAKE BLEEDING TOOL**  
IT MAKES EASIER THE BLEEDING OF BRAKES. THE SPECIAL VALVE PREVENTS AIR RETURNING INTO THE BRAKE SYSTEM WHILE BRAKE BLEEDING



## Art. 5396

**CHIAVE POLIGONALE DA 30 e 32 mm PER DADO TESTA FORCELLA MOTOCICLI**

**30 - 32 mm POLYGONAL MOTORCYCLES FORK CAP WRENCH**



**CHIAVE PER DADI BRACCI FORCELLA**  
**FORK CAPS WRENCH**

## Art. 5400

**CON OTTAGONI DA 46 E 50 mm**  
**WITH 46 AND 50 mm OCTAGONS**

## Art. 5402

**CON OTTAGONI DA 49 E 50 mm**  
**WITH 49 AND 50 mm OCTAGONS**



## ATTREZZO PIANTAGGIO GUARNIZIONE FORCELLA FORK SEAL DRIVER TOOL

TIPO APERTO  
OPEN TYPE



Art. 9145 STELI / STEMS  $\varnothing$  35 / 36

Art. 9146 STELI / STEMS  $\varnothing$  37

Art. 9147 STELI / STEMS  $\varnothing$  38

Art. 9149 STELI / STEMS  $\varnothing$  40

Art. 9150 STELI / STEMS  $\varnothing$  41

Art. 9152 STELI / STEMS  $\varnothing$  43

Art. 9154 STELI / STEMS  $\varnothing$  45

Art. 9155 STELI / STEMS  $\varnothing$  46 /  $\varnothing$  47

Art. 9157 STELI / STEMS  $\varnothing$  48

Art. 9159 STELI / STEMS  $\varnothing$  49 /  $\varnothing$  50

## Art. 9165

SET DI PIANTAGGI GUARNIZIONE FORCELLA  
CON 6 DIFFERENTI ADATTATORI DA  
 $\varnothing$  35 / 36 - 40 / 41 - 42 / 43 - 45 / 46 - 47 / 48 - 49 / 50  
E FLANGIA DI ACCOPPIAMENTO

FORK SEALS DRIVER TOOLS SET  
WITH 6 DIFFERENT SIZES ADAPTERS  
 $\varnothing$  35 / 36 - 40 / 41 - 42 / 43 - 45 / 46 - 47 / 48 - 49 / 50  
AND OPERATING FLANGE



CHIAVE TIRARAGGI COMPONIBILE - A DUE INNESTI  
UNITS SPOKE WRENCH - DOUBLE SOCKETS

Art. 4884 SOLO MANICO / ONLY HANDLE

Art. 4886 INNESTO / SOCKET mm. 5

Art. 4889 INNESTO / SOCKET mm. 5,6

Art. 4890 INNESTO / SOCKET mm. 5,8

Art. 4891 INNESTO / SOCKET mm. 6

Art. 4893 INNESTO / SOCKET mm. 6,4

Art. 4895 INNESTO / SOCKET mm. 6,8

Art. 4896 INNESTO / SOCKET mm. 6,9

## Art. 4921

CHIAVE TIRARAGGI A 6 IMBOCCHI  
SPOKE WRENCH WITH 6 OPEN END  
mm 5,6 - 5,7 - 6 - 6,3 - 6,6 - 6,8



## Art. 4920

CHIAVE TIRARAGGI DINAMOMETRICA  
CON 8 INNESTI DA 5.1mm., 5.8mm., 6.1mm., 6.3mm., 6.4mm., 6.5mm.,  
6.7mm., 6.9mm., INNESTO A 6 SCANALATURE E MANICO FISSO  
CAPACITÀ DI SERRAGGIO 2-7 Nm

DYNAMOMETRICAL SPOKE TORQUE WRENCH  
WITH 8 SPOKE HEADS OF 5.1mm., 5.8mm., 6.1mm., 6.3mm., 6.4mm., 6.5mm.,  
6.7mm., 6.9mm., ONE SPOKE HEAD-6PT SPLINE AND FIXED HANDLE  
2-7 Nm TORQUE CAPACITY



**LEVAGOMMA CON RIVESTIMENTO IN NYLON  
TYRE LEVER WITH NYLON COATING**

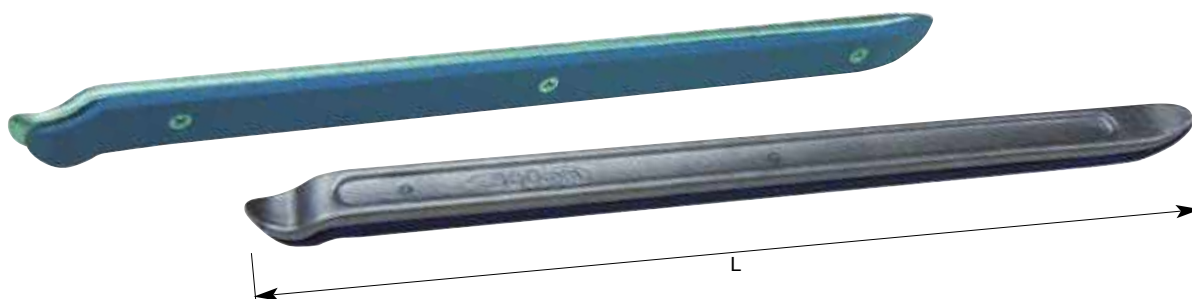

**Art. 4966**

**L = MM 380**  
IN ACCIAIO AL CARBONIO - PESO 0,420 KG  
IN CARBON STEEL - WEIGHT 0,420 KG

**Art. 4967**

**L = MM 500**  
IN ACCIAIO AL CROMO VANADIO - PESO 0,735 KG  
IN CHROME VANADIUM STEEL - WEIGHT 0,735 KG

**Art. 4970**



**LEVAGOMMA PER PNEUMATICI TALLONATI  
ACCIAIO AL CROMO MOLIBDENO - PESO 0,400 Kg**

**TYRE TOOL FOR OFF-ROAD TYRES  
CHROME MOLYBDENUM STEEL - WEIGHT 0,400 Kg**

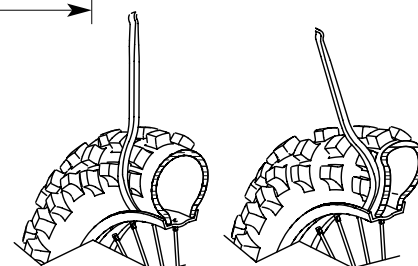

**Art. 4971**



**LEVAGOMMA EXTRALUNGO L = 530 mm**  
IN ACCIAIO AL CROMO VANADIO - PESO 0,965 KG  
CON PROTEGGI CERCHIONE SCORREVOLE IN NYLON  
**EXTRA LONG TYRE LEVER L = 530 mm**  
IN CHROME VANADIUM STEEL - WEIGHT 0.965 KG  
WITH RIM NYLON PROTECTIVE SLEEVE

**Art. 9220**

**PROTEGGI CERCHIONE SCORREVOLE IN NYLON PER ART. 4971  
RIM NYLON PROTECTIVE SLEEVE FOR ART. 4971**



**Art. 4965**

**NEW**

**LEVAGOMMA IN ACCIAIO MM. 440 CON IMPUGNATURA  
TYRE LEVER IN STEEL MM. 440 WITH HANDLE**



**DISPONIBILE DA APRILE 2023  
AVAILABLE FROM APRIL 2023**

**Art. 4956**

**SERIE LEVAGOMMA DI mm. 170**

In acciaio al carbonio forgiata, con impugnatura plasticata, serie di n. 3 pezzi

Tyre tool in carbonium steel, with plasticized handle, lenght mm. 170, set of n. 3 pcs.

Conf. / Pack 1 set



**Art. 4959**

**LEVAGOMMA DI mm. 200**

In acciaio al carbonio – Peso Kg. 0,145

In carbonium steel – Weight Kg. 0145

Conf. / Pack 5 pcs

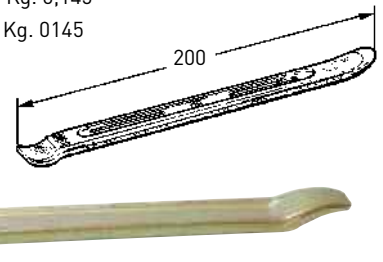

**Art. 4953**

**NEW**

**LEVAGOMMA DI mm. 200**

In acciaio al carbonio – Peso Kg. 0,09

In carbonium steel – Weight Kg. 0,09

Conf. / Pack 5 pcs

**DISPONIBILE DA APRILE 2023  
AVAILABLE FROM APRIL 2023**

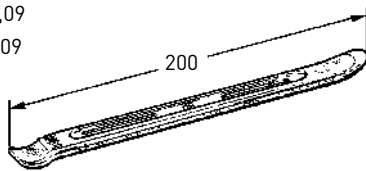

**Art. 4960**

**SERIE LEVAGOMMA DI mm. 200**

In acciaio al carbonio, serie di n. 3 pezzi, con gancio di fissaggio al raggio  
Tyre tool in carbonium steel, lenght mm. 200 set of n. 3 pcs., with hook blocking on the spoke

Conf. / Pack 1 set

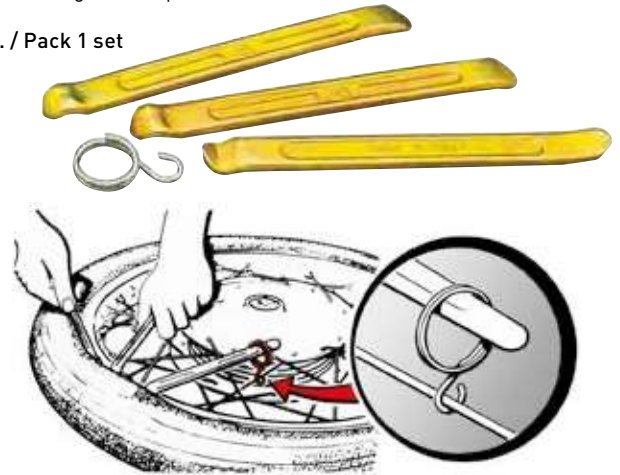

**Art. 4955**

**NEW**

**SERIE LEVAGOMMA DI mm. 200 – Peso Kg. 0,09 cad.**

In acciaio al carbonio, serie di n. 3 pezzi, con gancio di fissaggio al raggio

Tyre tool in carbonium steel, lenght mm. 200 - Weight Kg. 0,09 each, set of 3 pcs. with hook blocking on the spoke

Conf. / Pack 1 pc

**DISPONIBILE DA APRILE 2023 - AVAILABLE FROM APRIL 2023**



**Art. 4962**

**LEVAGOMMA DI mm. 240**

In acciaio cromo

In steel chrome

Conf. / Pack 5 pcs

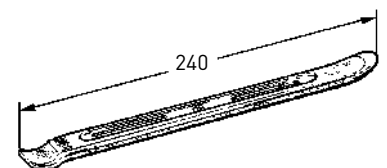

## Art. 4963

### SERIE LEVAGOMMA DI mm 240

In acciaio al cromo, serie di n. 3 pezzi, con gancio di fissaggio al raggio  
Tyre tool in steel chrome, length mm. 240, set of n. 3 pcs., with hook blocking on the spoke

Conf. / Pack 1 set

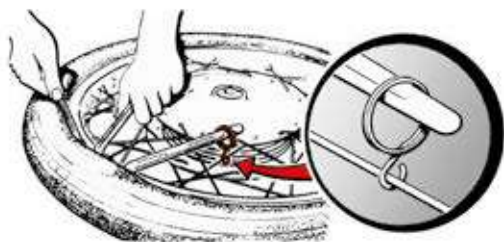

## Art. 4968

### LEVAGOMMA DI mm. 350 «PROFESSIONAL»

In acciaio al cromo / in steel chrome

Conf. / Pack 1 pc

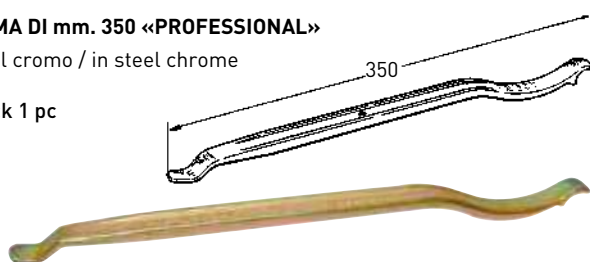

## Art. 4969

### SERIE LEVAGOMMA «PROFESSIONAL»

Serie formata da n. 2 levagomma di mm. 350 e n. 1 levagomma di mm. 240, in acciaio al cromo, con gancio di bloccaggio al raggio

Tyre tool «PROFESSIONAL» set, type with n. 2 tyre tools mm. 350 and n. 1 tyre tool mm. 240 in steel chrome, with hook blocking on the spoke

Conf. / Pack 1 set



## Art. 4974

### PINZA STACCA COPERTONE PER TUBE LESS TUBE LESS TYRE CRUSH TOOL BEAD BREAKER

Conf. / Pack 1 pc

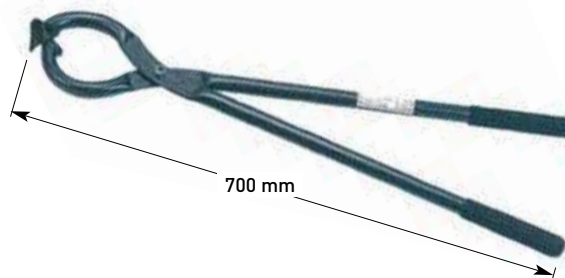

## Art. 4976

### STACCA COPERTONE DI mm 330

ATTREZZO PER SOLLEVARE IL COPERTONE.  
FACILITA L'INSERIMENTO DELLA VALVOLA  
PESO Kg 0,290

### mm 330 TYRE DETACHING TOOL

USEFUL TO LIFT THE TYRE. IT MAKES EASIER  
VALVE INTRODUCTION.  
WEIGHT kg. 0,290



## Art. 4979

### ATTREZZO BLOCCA COPERTONE TOOL TO LOCK THE TYRE BEADS



## Art. 4980

### ATTREZZO BLOCCA COPERTONE

Facilita il montaggio sulle ruote a raggi  
Istruzioni nella confezione

### TYRE LOCATING LEVER

Make easier the assembling on spoke wheels  
User instruction included

Conf. / Pack 1 pc

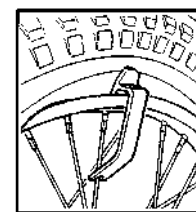

## Art. 4972

### COPPIA PROTEGGI CERCHIONE IN NYLON PAIR OF NYLON RIM PROTECTORS

Conf. / Pack 1 pc

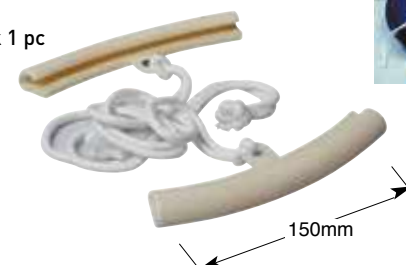

**Art. 4973**

**ATTREZZO MONTAGGIO/SMONTAGGIO VALVOLA DEL PNEUMATICO**  
TIRA IL GAMBO E TRASCINA NEL FORO LA GUARNIZIONE IN GOMMA  
IL MANICO A "T" PERMETTE DI INSTALLARE LA VALVOLA  
SENZA SOLLEVARLA OLTRE IL BORDO DEL CERCHIONE

**TYRE VALVE ASSEMBLING/DISASSEMBLING TOOL**

FOR PULLING RUBBER-COVERED VALVE INTO THE HOLE  
T-HANDLE ALLOWS INSTALLING THE VALVE WITHOUT LIFTING  
OVER THE RIM EDGE



**Art. 4975**

**ATTREZZO MONTAGGIO/SMONTAGGIO VALVOLA DEL PNEUMATICO CON GAMBO PIEGATO**  
AGGANCIA IL GAMBO DELLA VALVOLA  
LUNGHEZZA TOTALE ATTREZZO : 225 MM

**VALVE STEM ASSEMBLING/DISASSEMBLING TOOL**

HOLD THE VALVE STEM  
TOOL TOTAL LENGTH : 225 MM

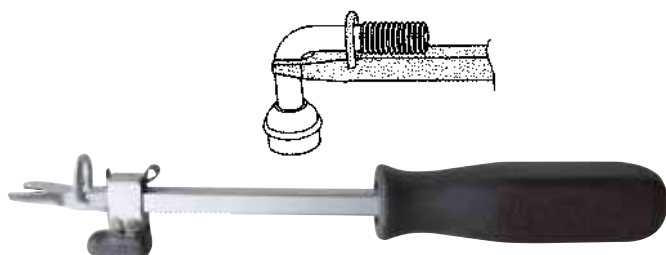

**Art. 4977**

**ATTREZZO PER RIMUOVERE LA VALVOLA DEL PNEUMATICO**  
UTILE PER SCARICARE RAPIDAMENTE L'ARIA

**TYRE VALVE STEM CORE REMOVER**

TO DISCHARGE RAPIDLY THE AIR

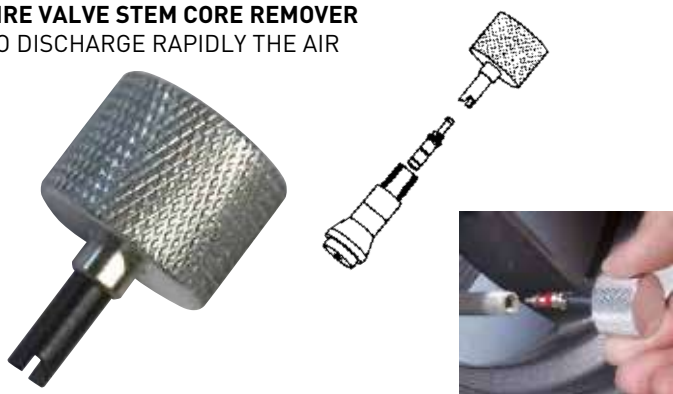

**Art. 0700**

**NEW**

**KIT RIPARAZIONE PNEUMATICI TUBELESS**

LA CONFEZIONE, IN COMODA BORSA DI NYLON, CONTIENE:  
1 PUNTERUOLO PER INSERIRE LA STRISCIA DI RIPARAZIONE  
1 PUNTERUOLO ELICOIDALE  
5 STICK RIPARAZIONE  
1 TUBO DI COLLA PER VULCANIZZAZIONE DA 8ML  
3 CARTUCCE CO2 DA 16G  
1 PROTEZIONE PER CARTUCCIA  
1 COLTELLINO  
1 RACCORDO FLESSIBILE E IMPUGNATURA

**TUBELESS TYRE REPAIR TOOL KIT**

THE PACKAGE, IN A HANDY NYLON BAG, CONTENTS :

1 T-HANDLE TO INSERT THE TYRE SEAL  
1 HELICAL T-HANDLE  
5 TYRE SEALS STICKS  
1 VULCANIZED GLUE 8ML  
3 CO2 16G CARTRIDGES  
1 CARTRIDGE PROTECTION  
1 KNIFE  
1 EXTENSION TUBE WITH HANDLE



**DISPONIBILE DA APRILE 2023  
AVAILABLE FROM APRIL 2023**

**Art. 9181**

**ATTREZZO A 4 ESAGONI PER BLOCCARE IL PERNO DELLA RUOTA ANTERIORE**

CON ESAGONO DA 17 - 19 - 22 - 24 MM

**4 HEXAGONES TOOL FOR LOCKING THE FRONT WHEEL AXLE**

WITH 17 - 19 - 22 - 24 MM HEXAGON



**Art. 9184**

**ATTREZZO A 6 ESAGONI PER BLOCCARE IL PERNO DELLA RUOTA ANTERIORE**

CON ESAGONI DA 12 - 14 - 17 - 19 - 22 - 24 MM

**6 HEXAGONES TOOL DESIGNED FOR LOCKING THE FRONT WHEEL AXLE**

WITH 6 DIFFERENT SIZES 12 - 14 - 17 - 19 - 22 - 24 MM



**Art. 0940**

**APPOGGIO SOTTORUOTA CON SFERE - GEOMETRIA VARIABILE**  
FACILITA LA ROTAZIONE MANUALE DELLE RUOTE E LO SPOSTAMENTO DEL MOTOCICLO NELLA ZONA DI ESPOSIZIONE

**UNDER-WHEELS BALLS SUPPORT - CHANGEABLE SHAPE**  
TO MAKE EASIER THE MANUAL ROTATION OF WHEELS AND MOTORCYCLE MOVING INSIDE THE SHOWROOM.

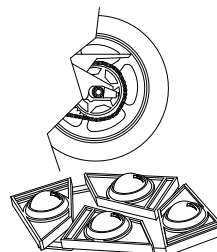

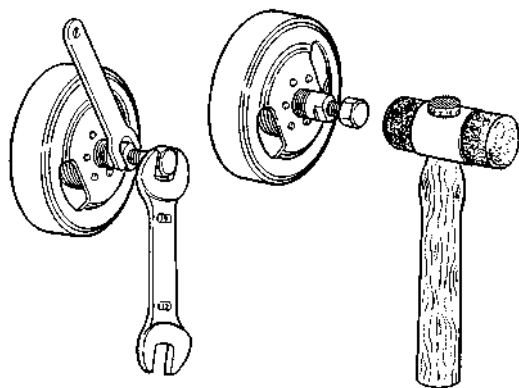

ESTRATTORI CON **FILETTO ESTERNO DESTRO** PER VOLANO MAGNETICO  
 PULLERS WITH **RIGHT OUTER THREAD** FOR MAGNETIC FLY-WHEEL



- |                  |                |                  |   |
|------------------|----------------|------------------|---|
| <b>Art. 5208</b> | Ø 18 x p. 1,5  | <b>Art. 5208</b> | Ø mm. 18 passo-pitch 1,5<br>YAMAHA CROSS 125/250  |
| <b>Art. 5209</b> | Ø 19 x p. 1    | <b>Art. 5209</b> | Ø mm. 19 passo-pitch 1<br>DUCATI ELETTRONICO  |
| <b>Art. 5211</b> | Ø 20 x p. 1    | <b>Art. 5211</b> | Ø mm. 20 passo-pitch 1<br>PEUGEOT   |
| <b>Art. 5218</b> | Ø 22 x p. 1    | <b>Art. 5218</b> | Ø mm. 22 passo-pitch 1<br>PEDIVELLE CICLO   |
| <b>Art. 5219</b> | Ø 22 x p. 1,5  | <b>Art. 5219</b> | Ø mm. 22 passo-pitch 1,5<br>BOSCH-DUCATI-MOTOPLATT  |
| <b>Art. 5220</b> | Ø 22 x p. 1,5  | <b>Art. 5220</b> | Ø mm. 22 passo-pitch 1,5<br><b>CON VITE LUNGA - WITH LONG SCREW</b><br><b>BMW dal/from 2010</b><br>CON VOLANO <b>NIPPODENSO</b><br>WITH <b>NIPPODENSO</b> FLY-WHEEL |
| <b>Art. 5224</b> | Ø 24 x p. 1    | <b>Art. 5224</b> | Ø mm. 24 passo-pitch 1<br>YAMAHA - MBK - PEUGEOT<br>- HONDA - KYMCO 50cc  |
| <b>Art. 5226</b> | Ø 24 x p. 1,5  | <b>Art. 5226</b> | Ø mm. 24 passo-pitch 1,5<br>ISCRA motori / engines<br>MORINI 50cc   |
| <b>Art. 5232</b> | Ø 26 x p. 1    | <b>Art. 5232</b> | Ø mm. 26 passo-pitch 1<br>KOKUSAN - MITSUBA - PIAGGIO<br>VESPA - GILERA - APRILIA - PEUGEOT   |
| <b>Art. 5234</b> | Ø 26 x p. 1,5  | <b>Art. 5234</b> | Ø mm. 26 passo-pitch 1,5<br>BOSCH-MOTOPLATT-SEM-DUCATI  |
| <b>Art. 5238</b> | Ø 27 x p. 1    | <b>Art. 5238</b> | Estrattore volano Ø mm. 27 passo 1 destro,<br>per Honda<br>Fly-wheel extractor Ø mm. 27 pitch 1 right<br>thread, for Honda<br>KOKUSAN                               |
| <b>Art. 5239</b> | Ø 27 x p. 1,25 | <b>Art. 5239</b> | Ø mm. 27 passo-pitch 1,25<br>MOTOPLATT-DUCATI   |
| <b>Art. 5242</b> | Ø 28 x p. 1    | <b>Art. 5242</b> | Ø mm. 28 passo-pitch 1<br>PIAGGIO-GILERA-VESPA<br>LML-125-150-200   |
| <b>Art. 5243</b> | Ø 28 x p. 1,25 | <b>Art. 5243</b> | Ø mm. 28 passo-pitch 1,25   |
| <b>Art. 5244</b> | Ø 28 x p. 1,5  | <b>Art. 5244</b> | Ø mm. 28 passo-pitch 1,5  |
| <b>Art. 5247</b> | Ø 30 x p. 1,5  | <b>Art. 5247</b> | Ø mm. 30 passo-pitch 1,5<br>MOTOPLATT   |
| <b>Art. 5254</b> | Ø 33 x p. 1,5  | <b>Art. 5254</b> | Ø mm. 33 passo-pitch 1,5<br>MOTOPLATT-FENSA   |

Conf. / Pack 2 pcs p. = passo / pitch



ESTRATTORI CON **DOPPIO FILETTO ESTERNO DESTRO** PER VOLANO MAGNETICO

PULLERS WITH **DOUBLE RIGHT OUTER THREAD** FOR MAGNETIC FLY-WHEEL

Conf. / Pack 2 pcs p. = passo / pitch

**Art. 5276**

Ø mm. 19 p1 - Ø mm. 22 p1,5  
DUCATI-BOSCH  
per / for MBK-DERBY-RIEJU

**Art. 5278**

Ø mm. 22 p1,5 - Ø mm. 26 p1,5  
BOSCH - DUCATI

**Art. 5280**

Ø mm. 24 p1 - Ø mm. 26 p1  
per / for MBK

**Art. 5283**

Ø mm. 26 p1 - Ø mm. 28 p1  
PIAGGIO - VESPA 125/150 2t-4t

**Art. 5288**

Ø mm. 26 p1,5 - Ø mm. 27 p1,25  
BOSCH-MOTOPLATT-DUCATI

ESTRATTORI CON **FILETTO ESTERNO SINISTRO** PER VOLANO MAGNETICO

PULLERS WITH **LEFT OUTER THREAD** FOR MAGNETIC FLY-WHEEL

Conf. / Pack 2 pcs p. = passo / pitch

**Art. 5250**

ESTRATTORE VOLANO Ø mm. 27 passo 1 SINISTRO  
FLY-WHEEL PULLER Ø mm. 27 pitch 1 LEFT  
KOKUSAN - HONDA-YAMAHA-MINARELLI  
SUZUKI-KAWASAKI-PEUGEOT - KYMCO -  
SYM -  
CPI SCOOTER  
PER VOLANI GIAPPONE-CINA  
FOR JAPAN-CHINA FLY-WHEEL



**Art. 5261**

ESTRATTORE VOLANO Ø mm. 18 passo 1 SINISTRO  
FLY-WHEEL PULLER Ø mm. 18 pitch 1 LEFT  
CPI 50cc 2t  
PER VOLANI GIAPPONE-CINA  
FOR JAPAN-CHINA FLY-WHEEL





## ESTRATTORI CON FILETTO INTERNO PULLERS WITH INTERNAL THREAD

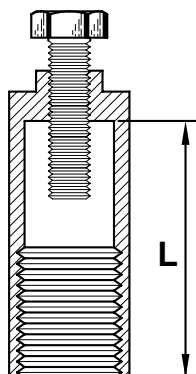

**Art. 5304** Ø 22 x p. 1 - L = 70 mm

**Art. 5380** Ø 24 x p. 1,5 - L = 75 mm

**Art. 5316** Ø 26 x p. 1 - L = 33 mm

**Art. 5319** Ø 28 x p. 1 - L = 45 mm

**Art. 5345** Ø 28 x p. 1 - L = 45 mm

**Art. 5381** Ø 28 x p. 1 - L = 75 mm

**Art. 5324** Ø 30 x p. 1 - L = 40 mm

**Art. 5337** Ø 30 x p. 1 - L = 91 mm

**Art. 5382** Ø 30 x p. 1,25 - L = 75 mm

**Art. 5327** Ø 30 x p. 1,5 - L = 40 mm

**Art. 5346** Ø 32 x p. 1,25 - L = 22 mm  
SINISTRO / LEFT

**NEW**

**Art. 5332** Ø 32 x p. 1,5 - L = 80 mm

**Art. 5334** Ø 33 x p. 1,5 - L = 55 mm

**Art. 5336** Ø 35 x p. 1 - L = 45 mm

**Art. 5340** Ø 35 x p. 1,5 - L = 40 mm

**Art. 5343** Ø 38 x p. 1,5 - L = 45 mm

**Art. 5344** Ø 39 x p. 1,5 - L = 50 mm

**Art. 5330** Ø 42 x p. 1,5 - L = 16 mm  
SINISTRO / LEFT

**NEW**

Conf. / Pack 1 pcs p. = passo / pitch

## per / for HONDA

**Art. 5304** Ø mm 22 x 1 - L = 70 mm  
HONDA CUBE 100

**Art. 5319** Ø mm 28 x 1 prod. fino/till 2008  
HONDA CROSS 125-250 2t  
HONDA MOTARD serie / series  
TRX 250-450 4t  
KAWASAKI KRX - SUZUKI DRZ

**Art. 5327** Ø mm 30 x 1,5  
HONDA 125-150-250 4t

**Art. 5332** Ø mm 32 x 1,5  
Puleggia dentata dell' avviamento  
Toothed starter gear  
HONDA 125-150 4t scooter

**Art. 5334** Ø mm 33 x 1,5  
con puntale / with push rod **Art. 5312**  
HONDA SH 300 4t - KTM - SUZUKI  
- YAMAHA WR - YZ 450 F - BMW

**Art. 5380** Ø mm 24 x 1,5  
con puntale / with push rod **Art. 5312**  
HONDA CRF 250-450 4t  
CROSS - ENDURO - SUPERMOTARD

**Art. 5381** Ø mm 28 x 1  
con puntale / with push rod **Art. 5312**  
HONDA CROSS - ENDURO -  
MOTARD 125/250 4t  
prod. dal/from 2009

**Art. 5382** Ø mm 30 x 1,25  
con puntale / with push rod **Art. 5312**  
HONDA CRF 250-450 4t  
CROSS - ENDURO - SUPERMOTARD  
KAWASAKI KX - SUZUKI RM -  
YAMAHA YZ

## per / for KAWASAKI-KYMCO-SUZUKI

**Art. 5319** Ø mm 28 x 1  
KAWASAKI KLX - SUZUKI DRZ -  
HONDA CROSS 125-250 2t  
HONDA MOTARD TRX 250-450 4t

**Art. 5334** Ø mm 33 x 1,5  
con puntale / with push rod **Art. 5312**  
SUZUKI - BMW  
HONDA SH 300 4t - KTM YAMAHA  
WR - YZ 450 F

**Art. 5343** Ø mm 38 x 1,5  
KAWASAKI KLX - KSF - BMW  
SUZUKI DR - BURGMAN -  
BOMBARDIER/APRILIA

**Art. 5344**

Ø mm 39 x 1,5  
con puntale filettato / with threaded push rod  
Art. 5308  
KYMCO 300-500 4t - scooter

**Art. 5345**

Ø mm 28 x 1  
con puntale filettato / with threaded push rod  
Art. 5308  
KYMCO 250 4t

**Art. 5382**

Ø mm 30 x 1,25  
con puntale / with push rod Art. 5312  
KAWASAKI KX - SUZUKI RM -  
HONDA CRF 250-450 4t  
CROSS-ENDURO-SUPERMOTARD  
YAMAHA YZ

per / for **KTM**

**Art. 5316**

Ø mm 26 x 1  
KTM vari modelli/various model  
- 125-250 2t

**Art. 5330**

Ø mm 42 x 1,5 SINISTRO / LEFT **NEW**  
KTM DUKE/RC 390

**Art. 5334**

Ø mm 33 x 1,5  
con puntale / with push rod Art. 5312  
KTM vari modelli/various model  
HONDA SH 300 4t - SUZUKI-  
YAMAHA WR - YZ 450 F -  
BMW

**Art. 5346**

Ø mm 32 x 1,25 SINISTRO / LEFT **NEW**  
KTM DUKE/RC 125-200

per / for **PIAGGIO**

**Art. 5336**

Ø mm 35 x 1  
volano / fly-wheel DUCATI  
per motori for engines  
PIAGGIO 250-400-500 4t

**Art. 5337**

Ø mm 30 x 1  
con puntale / with push rod  
VESPA PRIMAVERA 125-150 4t dal/from 2014  
VESPA SPRINT 125-150 4t  
PIAGGIO LIBERTY 125-150  
motori/engines 4t 3V  
anche per / also for  
VESPA LX 125-150  
VESPA S 125-150



per / for **ROTAX**

**Art. 5340**

Ø mm 35 x 1,5  
volano / fly-wheel BOSCH-RCPIIL  
per / for ROTAX 125/250  
YAMAHA vecchi modelli /old models

per / for **YAMAHA**

**Art. 5324**

Ø mm 30 x 1  
YAMAHA WR-YZ 250 F

**Art. 5334**

Ø mm 33 x 1,5  
con puntale / with push rod Art. 5312  
YAMAHA WR-YZ 450 F - BMW  
HONDA SH 300 4t - KTM - SUZUKI

**Art. 5340**

Ø mm 35 x 1,5  
volano / fly-wheel BOSCH-RCPIIL  
YAMAHA vecchi modelli /old models  
ROTAX 125/250

**Art. 5382**

Ø mm 30 x 1,25  
con puntale / with push rod Art. 5312  
YAMAHA YZ - HONDA CRF 250-450 4t  
CROSS-ENDURO-SUPERMOTARD  
KAWASAKI KX - SUZUKI RM

**PUNTALI PER ESTRATTORI VOLANO  
FLY-WHEEL PULLERS PUSH RODS**

**Art. 5308**

PUNTALE FILETTATO PER VOLANO KYMCO  
THREADED PUSH FOR KYMCO FLY-WHEEL

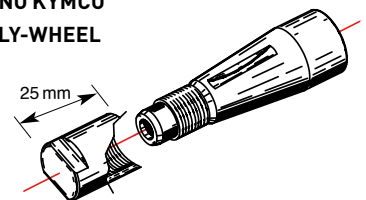

**Art. 5312**

PUNTALE FILETTATO PER ESTRATTORI HONDA  
THREADED PUSH ROD FOR HONDA PULLERS

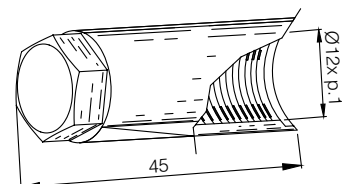

## Art. 5360

### ESTRATTORE UNIVERSALE

PER LO SMONTAGGIO DEL MOZZO FRIZIONE, DI ALCUNI TIPI DI ALTERNATORE, DI INGRANAGGI E PIGNONI

### UNIVERSAL PULLER

TO REMOVE THE CLUTCH HUB, SOME ALTERNATORS, GEARS AND SPROCKETS



## Art. 5370

### ESTRATTORE VOLANO COMPLETO DI 6 VITI M8X100 E M8X150 CON PUNTALE SALVAFILETTO

FLY WHEEL PULLER COMPLETE WITH 6 SCREWS M8X100 AND M8X150 WITH PROTECTOR CAP

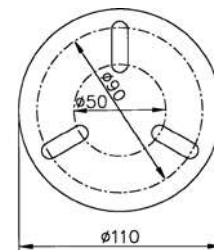

## Art. 5362

### ESTRATTORE PER VOLANI, ROTORI E INGRANAGGI AVVIAMENTO

COMPLETE WITH 3 SCREWS 6x25, 3 SCREWS 8x40, HANDLE AND CENTRAL SCREW

### FLYWHEEL, ROTORS AND STARTER GEARS PULLER TOOL



## Art. 5374

### ESTRATTORE VOLANO A 4 ASOLE

per motori/for engines SUZUKI - MINARELLI da/from 50 a/till 250cc

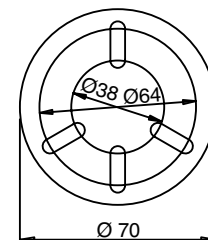

## Art. 5358

ESTRATTORE VOLANO MAGNETICO PER MOTORI SUZUKI

COMPLETE WITH 3 SCREWS M5, DRIVE BOLT AND HANDLE

### MAGNETIC FLYWHEEL PULLER FOR SUZUKI ENGINES

COMPLETE WITH 3 SCREWS M5, DRIVE BOLT AND HANDLE



## Art. 5376

### ESTRATTORE VOLANO a 3 viti per motori

per motori/for engines YAMAHA - MINARELLI - SUZUKI

FLY WHEEL PULLER with 3 screws for YAMAHA - MINARELLI - SUZUKI engines

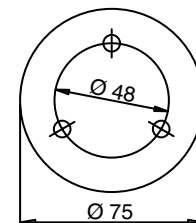

## Art. 5491

ESTRATTORE UNIVERSALE Per VOLANI DUCATI - SUZUKI 50cc - per FRIZIONE YAMAHA - MINARELLI 50cc e PUCH 50cc

UNIVERSAL EXTRACTOR For FLY-WHEEL DUCATI - SUZUKI 50 - for YAMAHA - MINARELLI 50cc - PUCH 50cc CLUTCH BODY

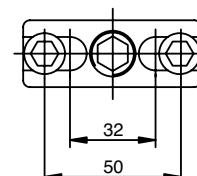











**buzzetti®**

**RICAMBI - ATTREZZI MOTO E SCOOTER  
MOTORCYCLE AND SCOOTER SPARE PARTS - TOOLS**

**[www.buzzetti.com](http://www.buzzetti.com)**